

**TECHNICAL MANUAL**

**OPERATOR'S, ORGANIZATIONAL,  
DIRECT SUPPORT, AND GENERAL  
SUPPORT MAINTENANCE MANUAL,  
INCLUDING REPAIR PARTS:**

**TEST SET,  
GUIDED MISSILE SYSTEM**

**CALIBRATION KIT (4931-01-003-2703)**

**APN 7915881**

**HUGHES AIRCRAFT COMPANY**

**PART NUMBER 1089933**

---

**HEADQUARTERS, DEPARTMENT OF THE ARMY**

**JUNE 1984**

**This manual is an authentication of the manufacturer's commercial literature which, through usage, has been found to cover the data required to operate and maintain this equipment. Since the manual was not prepared in accordance with military specifications, the format has not been structured to consider level of maintenance, nor to include a formal section on depot overhaul standards.**

**This manual contains copyrighted information that is printed with permission of Hughes Aircraft Company, Culver City, CA 90230.**

OPERATOR'S, ORGANIZATIONAL, DIRECT SUPPORT, AND

GENERAL SUPPORT MAINTENANCE MANUAL

INCLUDING REPAIR PARTS:

TEST SET, GUIDED MISSILE SYSTEM

CALIBRATION KIT 4931-01-003-2703

APN 7915881

HUGHES AIRCRAFT COMPANY PART NUMBER 1089933

**REPORTING OF ERRORS**

You can help improve this publication by calling attention to errors and by recommending improvements and stating your reasons for the recommendations. Your letter or DA Form 2028, Recommended Changes to Publications, should be mailed directly to Commander, US Army TMDE Support Group, ATTN: DRXTM-LML, Redstone Arsenal, AL 35898. A reply will be furnished directly to you.

		Paragraph	Page
CHAPTER	0. IDENTIFICATION AND DESCRIPTION		
	Scope .....	0-1	0-1
	Indexes of publications .....	0-2	0-1
	Forms and records .....	0-3	0-1
CHAPTER	1. INTRODUCTION		
Section	I. General information		
	Scope .....	1-1	1-1
	Maintenance forms and records .....	1-2	1-1
	Destruction of Army materiel to prevent enemy use.....	1-3	1-1
	Administrative storage .....	1-4	1-1
	Reporting errors and improvements .....	1-5	1-1
	Nomenclature cross-reference .....	1-6	1-2
	List of abbreviations .....	1-7	1-2
	II. Equipment Description and Data		
	System description .....	1-8	1-2
	Major unit description .....	1-9	1-4
CHAPTER	2. EQUIPMENT OPERATION .....		2-1

		Paragraph	Page
CHAPTER	3. OPERATING PROCEDURES		
	Controls and indicators .....	3-1	3-1
	System checkout .....	3-2	3-3
	Operating instructions .....	3-3	3-8
	4. MAINTENANCE INSTRUCTIONS FOR CALIBRATION CONTROL		
	General .....	4-1	4-1
	Tools and test equipment .....	4-2	4-1
	Preventive maintenance checks and services (PMCS) .....	4-3	4-1
	Troubleshooting.....	4-4	4-2
	Calibration .....	4-5	4-7
	Schematics and circuit card A101 component location .....	4-6	4-7
	5. MAINTENANCE INSTRUCTIONS FOR TSEM SHEAR PIN CALIBRATION TESTER		
	General .....	5-1	5-1
	Calibration.....	5-2	5-1
	6. PARTS LIST		
	TSGMS calibration kit parts list .....	6-1	6-1
	Circuit card A101 parts list .....	6-2	6-3
	LAMBDA power supply parts list .....	6-3	6-4
APPENDIX	A. CALIBRATION PROCEDURE FOR CALIBRATION CONTROL (HAC P/N 1090109)		
Section	I. Identification and Description		
	Test instrument identification .....		A-1
	Calibration data card, DA Form 2416 .....		A-1
	Calibration description.....		A-1
	II. Equipment Requirements		
	Equipment required .....		A-2
	Accessories required .....		A-2
	III. Preliminary Operations		
	Preliminary instructions .....		A-5
	Calibration control setup .....		A-5
	TI signal processor .....		A-5
APPENDIX	B. CALIBRATION PROCEDURE FOR TSEM SHEAR PIN CALIBRATION TESTER.....		B-1
Section	I. Identification and Description		
	Test instrument identification. ....		B-1
	Calibration data card, DA Form 2416 .....		B-1
	Calibration description .....		B-1
Section	II. Equipment Requirements		
	Equipment required .....		B-2
	Accessories required .....		B-2
Section	III. Calibration Process		
	Preliminary instructions .....		B-4
	Equipment setup .....		B-4
	C. REFERENCES .....		C-1
	D. BASIC ISSUE ITEMS LIST.....		D-1
	E. MAINTENANCE ALLOCATION CHART (MAC)		
	General .....		E-1
	Maintenance functions .....		E-1
	Explanation of format .....		E-2
	F. PRIOR MODIFICATIONS/ALTERATIONS .....		F-1

## CHAPTER 0

### INTRODUCTION

---

#### 0-1 Scope

This manual includes installation and operation instructions and covers operator, organizational, direct support (DS), and general support (GS) maintenance. It describes the TSGMS Calibration Kit, Hughes Aircraft Company, part number 1089933. This manual includes field changes in appendix F incorporated in calibration kits deployed prior to October 1982.

#### 0-2 Indexes of Publications

**DA Pam 310-1.** Refer to the latest issue of DA Pam 310-1 to determine if there are any new editions, changes, or additional publications pertaining to the equipment.

#### 0-3 Forms and Records

**a. Reports of Maintenance and Unsatisfactory Equipment.** Use equipment forms and records in accordance with instructions given in TM 38-750.

**b. Report of Packaging and Handling Deficiencies.** Fill out and forward SF 364, Report of Discrepancy (ROD), as prescribed in AR 735-11-2 (Army), NAVMATINST 4355.73A (Navy), AFR 400-54 (Air Force), and MCO 4430.3F (Marine Corps).

**c. Discrepancy in Shipment Report.** Fill out and forward SF 361, Discrepancy in Shipment Report (DISREP), as prescribed in AR 55-38 (Army), NAVSUPINST 4610.33C (Navy), AFR 75-18 (Air Force), and MCO P4610.19D (Marine Corps).

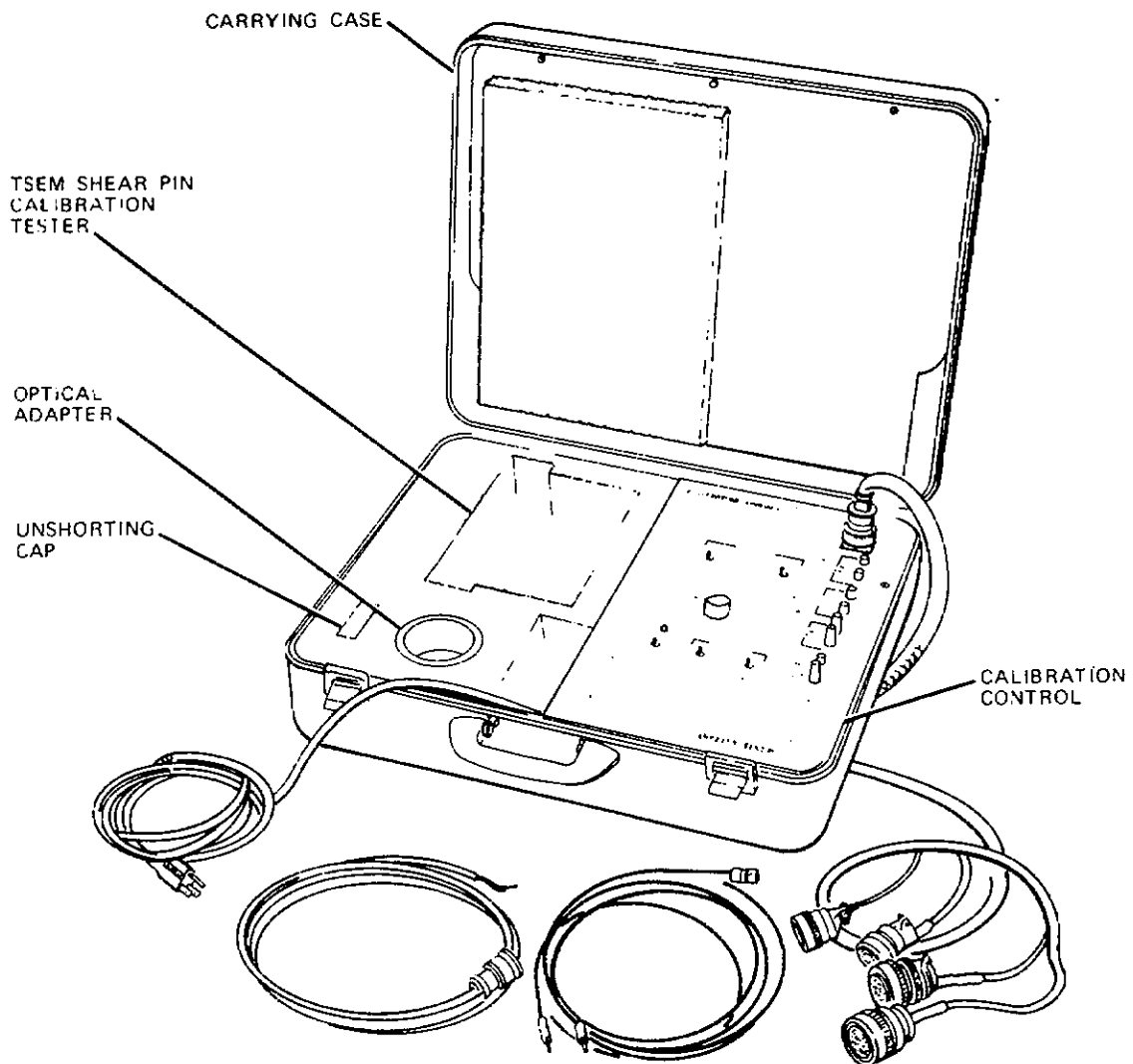

TSGMS (TEST SET, GUIDED MISSILE SYSTEM) CALIBRATION KIT,  
HUGHES AIRCRAFT P/N 1089933

CHAPTER 1

INTRODUCTION

Section I. GENERAL INFORMATION

Section II. EQUIPMENT DESCRIPTION AND DATA

<u>Para</u>		<u>Page</u>	<u>Para</u>		<u>Page</u>
1-1	Scope .....	1-1	1-8	System Description .....	1-2
1-2	Maintenance Forms and Records .....	1-1	1-9	Major Unit Description .....	1-4
1-3	Destruction of Army Materiel to Prevent Enemy Use	1-1			
1-4	Administrative Storage .....	1-1			
1-5	Reporting Errors and Improvements	1-1			
1-6	Nomenclature Cross-Reference .....	1-2			
1-7	List of Abbreviations .....	1-2			

SECTION I. GENERAL INFORMATION

1-1. SCOPE

Type of Manual: Instruction Manual

Equipment Name: TSGMS Calibration Kit

Purpose of Equipment:

- a. Used for calibration of TSGMS Monitor and Control Unit (MCU)
- b. Used for calibration of TSGMS Tow System Evaluation Missile (TSEM)
- c. Used for calibration of TSSGS IR Target Assembly (IRTA)

Special Limitations of Equipment: Used for production models of TSGMS only.

1-2. MAINTENANCE FORMS AND RECORDS

General: Prescribed by TN 38-750.

Reports of Accidents: Any accident that injures personnel or damages equipment shall be reported as required by AR 385-40.

1-3. DESTRUCTION OF ARMY MATERIEL TO PREVENT ENEMY USE

TSGMS Calibration Kit is not classified and should be destroyed with a weapon or heavy object only after destruction of all classified equipment has been completed.

1-4. ADMINISTRATIVE STORAGE

See TM 740-90-1 for requirements and procedures.

1-5. REPORTING ERRORS AND IMPROVEMENTS

Every effort is made to keep your manual current. Review conferences with using personnel and a constant review of accident and test reports assure the latest data in your manual.

We cannot correct an error unless we know of its existence. In this regard, it is essential that you do your part. Comments, corrections, and questions regarding this manual or any phase of the manual program are welcomed.

1-6. NOMENCLATURE CROSS-REFERENCE

<u>OFFICIAL NOMENCLATURE</u>	<u>P/N</u>	<u>COMMON NAME</u>
TSGMS Calibration Kit	1089933	Cal Kit
Calibration Control	1090109	Calibration Control
TSEM Shear Pin Calibration Tester	1069938-1	Calibration Fixture
Optical Adapter	7913485 (GFE)	Optical Adapter
Umbilical Unshorting Cap	7913478 (GFE)	Unshorting Cap
Carrying Case	X40787 (Zero Mfg. Co.)	Carrying Case

1-7. LIST OF ABBREVIATIONS

<u>ABBREVIATION</u>	<u>DEFINITION</u>
Ampl	Amplifier
Az	Azimuth
Cmd	Command
CVAC	Continually variable amplitude carrier
GFE	Government furnished equipment
HAC	Hughes Aircraft Company
IRTA	Infrared Target Assembly (Part of TSGMS)
MCU	Monitor and Control Unit (Part of TSGMS)
P/N	Part number
Ref	Reference
SCA	Stabilization Control Amplifier (Part of M-65)
Sig	Signal
TBD	To Be Determined
TSEM	TOW System Evaluator Missile (Part of TSGMS)
TSGMS	Test Set, Guided Missile System
TSU	Telescopic Sight Unit (Par: of M-65)
Vpp	Voltage peak-to-peak
Vrms	Voltage root-mean-squared
M-65	Armament Subsystem, Helicopter, TOW Guided Missile

SECTION II. EQUIPMENT DESCRIPTION AND DATA

1-8. SYSTEM DESCRIPTION

Purpose: Used for calibration of TSGMS:

- a. MCU b. TSGM c. IRTA

Capabilities and Features:

- All cal kit components are contained in a hand-portable aluminum weather-resistant case.
  - Length - 21 inches
  - Width - 17 inches
  - Height - 7.5 inches
  - Weight - 34 pounds, 4 ounces
- Cal kit consists of five components:
  - Calibration Control - HAC P/N 1090109
  - TSEM Shear Pin Calibration Tester - HAC P/N 1089938-1
  - Optical Adapter - MICOM P/N 7913485 (GFE)
  - Unshorting Cap - MICOM P/N 7913478 (GFE)
  - Carrying Case - HAC P/N 1089931



- Input/output characteristics of calibration control are:

a. BANDPASS signal

**NOTE**

**Refer to drawing number  
10189614 for 1.67 f<sub>0</sub>.**

- Input - Sinewave  $20 \pm 1$  Hz,  $2 \pm 0.1$  Vrms  
-  $1.67 f_0 \pm 0.5$  kHz,  $1.414 \pm 0.005$  Vms
- Output -  $1.67 f_0$  toneburst coincident with 20 Hz sinewave

b. SERVO signal

- Input - Sinewave  $35 \pm 1$  Hz,  $1.00 \pm 0.05$  Vrms
- Output - Two 35 Hz sinewaves, one lags the other by  $140 \pm 1^\circ$ .

c. START/STOP signals for MCU+  $9.5 \pm 0.5$  V

d. TSEM WIRE SIG

- Input - Squarewave  $870 \pm 1$  Hz, 35.5 V p-p  
- Sinewave  $560 \pm 1$  Hz,  $8 \pm 1$  V p-p
- Output - Modulated squarewave signal of 35.5 V p-p

Logistical Data

- Operating Environment
  - Temperature -  $0^\circ\text{C}$  to  $+50^\circ\text{C}$  ambient
  - Humidity - 50% ambient
  - Altitude - 10,000 feet maximum
- Power Requirements - 105 to 132 Vac, 57 to 63 Hz
- Storage Temperature -  $-25^\circ\text{C}$  to  $+85^\circ\text{C}$

Calibration Standards Required - the following equipment is required in addition to the cal kit when calibrating TSGMS:

- Ac voltage calibrator - Hewlett-Packard, Model C90-745A/746A (MIS-10342)
- Resistance standard - Biddle, Model 71-631 (7910328)
- Frequency counter - Hewlett-Packard, Model 5345A (MIS-28754/1 type 1)
- Dc current shunt - Guildline, Model 9711 (7912323)
- Dc voltage standard - John Fluke, Model 332B/332BAF (7911393)
- Differential voltmeter - John Fluke, Model 887( )
- Distortion analyzer - Hewlett-Packard, Model 334A (7911957)
- Signal generator - Wavetek, Model 145 (7915944) and Krohn-Rite, Model 4100AR-8 (7915951)
- Oscilloscope - Tektronix, Type 5440 with 5B42 and 5A13N (MIS-28706)
- Dc power supply - NJE Corp, Model CS36CR30 (7907346-2)
- Test oscillator - Hewlett-Packard, Model 652A
- Digital voltmeter - Hewlett-Packard, Model 3490A (7912606)
- Miscellaneous leads, adapters, jacks, and connectors as defined in TB 9-4935-473-50-1

1-9. MAJOR UNIT DESCRIPTION



**CALIBRATION CONTROL IN CARRYING CASE**

CALIBRATION CONTROL GENERATES AND PROCESSES THE ELECTRICAL SIGNALS REQUIRED TO CALIBRATE THE MCU AND THE TSEM.

CARRYING CASE ALLOWS HAND-PORTABILITY OF THE ENTIRE CAL KIT AS A SINGLE ENTITY.

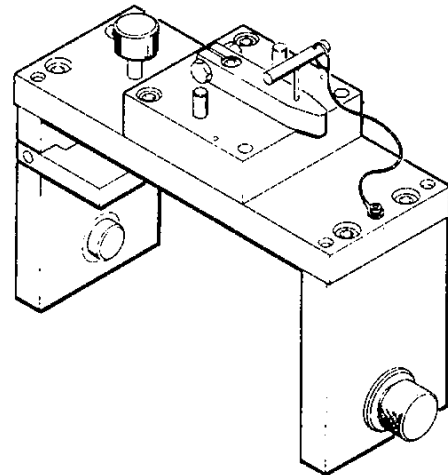

**TSEM SHEAR PIN CALIBRATION TESTER**

PROVIDES PRECISE MEASUREMENTS FOR CALIBRATION OF THE TSEM SHEAR PIN SENSOR ASSEMBLY.

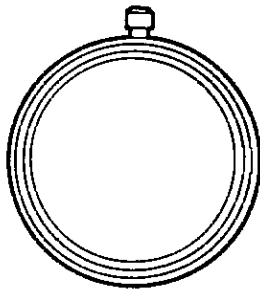

**OPTICAL ADAPTER**

ADAPTS RADIOMETER FIXED-AT-INFINITY FOCUS TO ALLOW VARIABLE FOCUS FOR CALIBRATION OF THE IRTA.

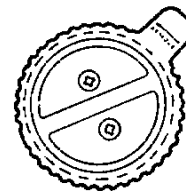

**UNSHORTING CAP**

USED TO UNSHORT CONNECTIONS IN THE TSEM UMBILICAL CONNECTOR TO ALLOW FOR CALIBRATION OF THE TSEM.



CHAPTER 3  
OPERATING PROCEDURES

<u>Para</u>		<u>Page</u>
3-1	Controls and Indicators .....	3-2
3-2	System .....	3-3
3-3	Operating Instructions .....	3-8

**3-1. CONTROLS AND INDICATORS**

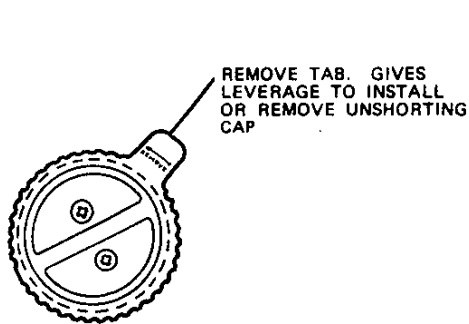

**UNSHORTING CAP**

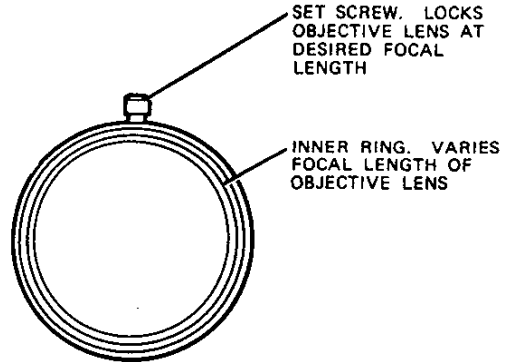

**OPTICAL ADAPTER**

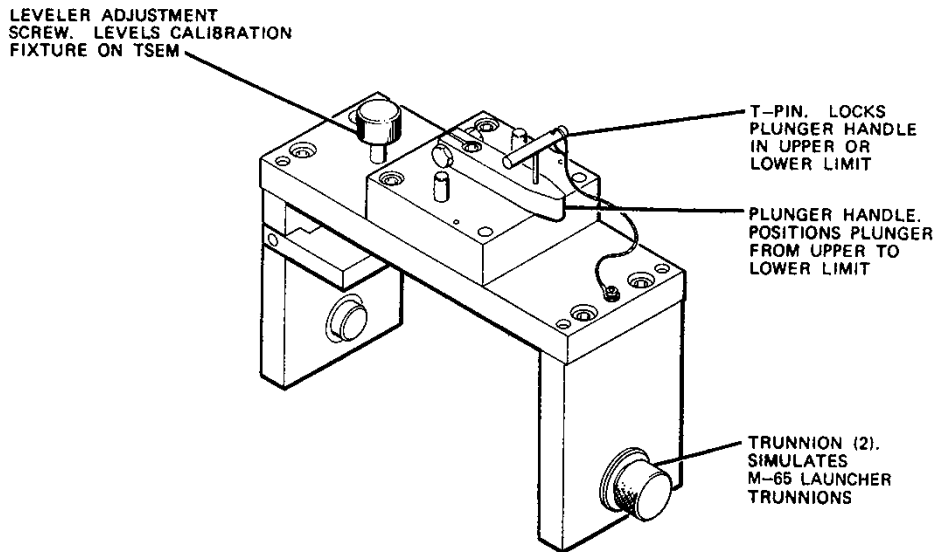

**TSEM SHEAR PIN CALIBRATION TESTER**

6-208-04A

3-1. CONTROLS AND INDICATORS (CANT)

6-208-05A

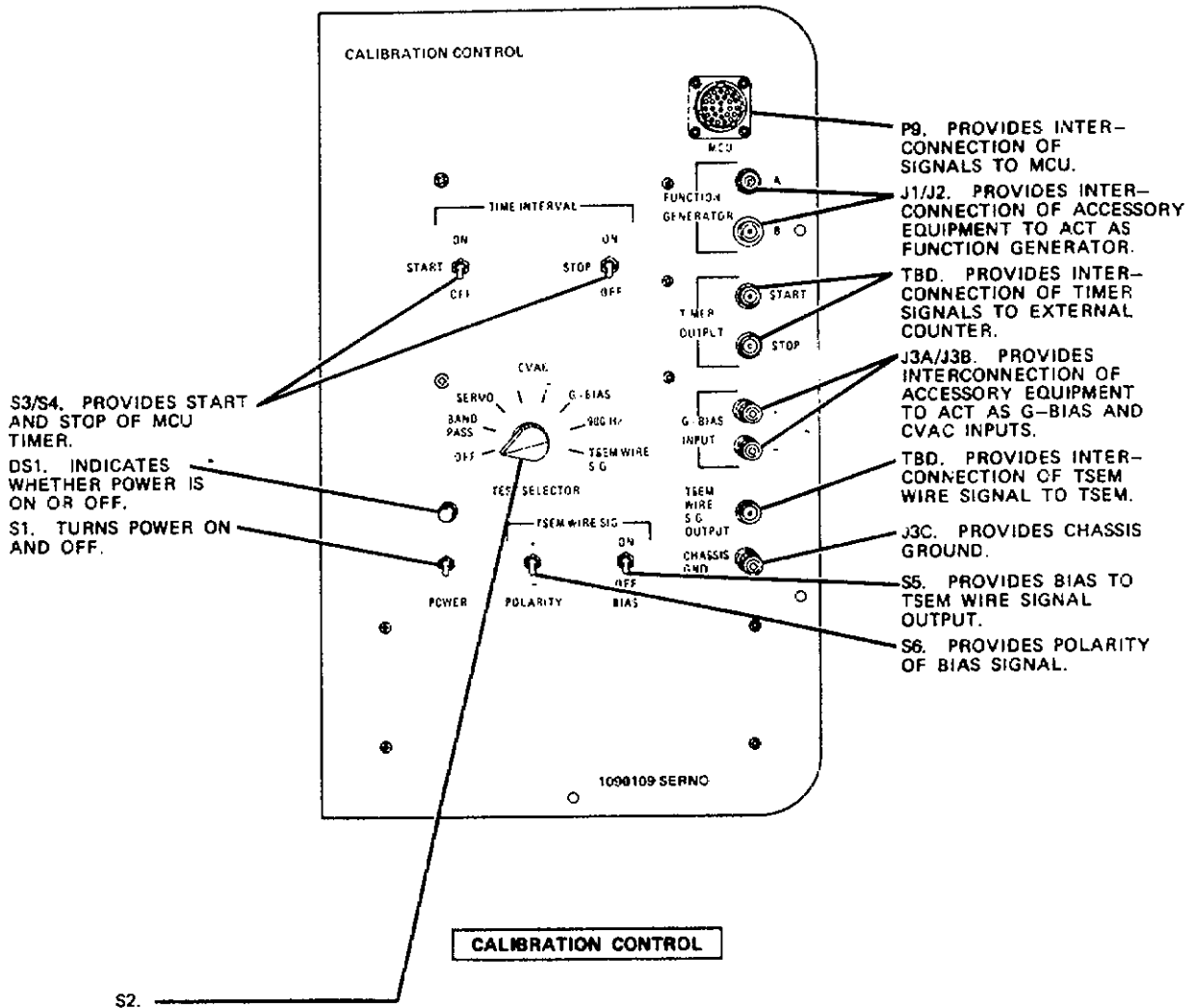

S3/S4. PROVIDES START AND STOP OF MCU TIMER.  
 DS1. INDICATES WHETHER POWER IS ON OR OFF.  
 S1. TURNS POWER ON AND OFF.

P9. PROVIDES INTER-CONNECTION OF SIGNALS TO MCU.  
 J1/J2. PROVIDES INTER-CONNECTION OF ACCESSORY EQUIPMENT TO ACT AS FUNCTION GENERATOR.  
 TBD. PROVIDES INTER-CONNECTION OF TIMER SIGNALS TO EXTERNAL COUNTER.  
 J3A/J3B. PROVIDES INTERCONNECTION OF ACCESSORY EQUIPMENT TO ACT AS G-BIAS AND CVAC INPUTS.  
 TBD. PROVIDES INTER-CONNECTION OF TSEM WIRE SIGNAL TO TSEM.  
 J3C. PROVIDES CHASSIS GROUND.  
 S5. PROVIDES BIAS TO TSEM WIRE SIGNAL OUTPUT.  
 S6. PROVIDES POLARITY OF BIAS SIGNAL.

- OFF. USED WHEN NO INPUTS TO MCU OR TSEM ARE DESIRED.
- BANDPASS. USED IN CONJUNCTION WITH EXTERNAL ACCESSORY EQUIPMENT TO SIMULATE M-65 TSU BANDPASS AND AZIMUTH REFERENCE SIGNALS.
- SERVO. USED IN CONJUNCTION WITH EXTERNAL ACCESSORY EQUIPMENT TO SIMULATE M-65 SCA ELEVATION OUTPUT AND ELEVATION ERROR SIGNALS.
- CVAC +/- . USED IN CONJUNCTION WITH EXTERNAL ACCESSORY EQUIPMENT TO APPLY CVAC INPUTS.
- G-BIAS. USED IN CONJUNCTION WITH EXTERNAL ACCESSORY EQUIPMENT TO APPLY G-BIAS INPUTS.
- 900 Hz. USED IN CONJUNCTION WITH EXTERNAL ACCESSORY EQUIPMENT TO APPLY 900 Hz INPUTS.
- TSEM WIRE SIG. USED IN CONJUNCTION WITH EXTERNAL ACCESSORY EQUIPMENT TO APPLY CALIBRATION SIGNAL TO TSEM.

**3-2. SYSTEM CHECKOUT**

The following procedures cover checkout of the calibration control, TSEM shear pin calibration tester, optical adapter, and unshorting cap.

INITIAL SETUP

General Safety: Read and follow safety instructions inside front cover.

- Equipment Required:
- a. All cal kit equipment listed in paragraph 1-9.
  - b. 115 V ac 60 Hz source
  - c. Light machine oil or dry lube
  - d. Function generator (2 required); HP3300A with HP3302A plug-in, or equivalent
  - e. DC source; HP62278 Dual dc power supply, or equivalent
  - f. Digital multimeter (DMM); Join Fluke 8375A, or equivalent
  - g. Timer-Counter; HP5326A, or equivalent
  - h. Oscilloscope; HP181A with 1801A and 1821A Plug-ins, or equivalent
  - i. 20K ohm 1/4 watt resistor
  - j. 2000 pf capacitor

Location	Item	Action	Normal Indication	Corrective Action IF indication Abnormal
<b>NOTE</b>				
<b>This inspection constitutes checkout for all items but calibration control.</b>				
1. Cal Kit	a. All items	Remove from carrying case	...	...
	b. Calibration control	Visually inspect	Clean, unbroken	Clean, refer to Chapter 4
	c. Shear pin calibration tester	Visually inspect	Clean, unbroken	Clean, refer to Chapter 5
	d. Optical adapter	Visually inspect	Clean, focuses freely to Depot	Clean, lubricate, refer
	e. Unshorting cap	Visually inspect	Clean, unbroken	Clean, refer to Depot
<b>WARNING</b>				
<b>High voltages are present in the calibration control. Avoid contact with exposed components.</b>				
<u>CALIBRATION CONTROL POWER CHECK</u>				
2. Calibration control	a. POWER	Off	...	...
	b. TEST SELECTOR	OFF	...	...
	c. TIME INTERVAL START	OFF	...	...
	d. TIME INTERVAL STOP	OFF	...	...
	e. Ac power cable	Connect to 115 V ac 60 Hz source	...	...
	f. POWER	On	Power indicator illuminates	Troubleshoot per para 4-4, Part 1
	g. Lambda power supply	Verify 115V, -15V, +5V outputs using digital multimeter	a. +15 ± 0.2V b. -15 ± 0.2V c. +5 ± 0.1V	Troubleshoot per para 4-4, Part 1
<u>CALIBRATION CONTROL 140° PHASE SHIFT CHECK</u>				
3. Calibration Control	a. FUNCTION GENERATOR A	Connect HP3000A function generator	...	...
	b. TEST SELECTOR	SERVO	...	...
4. HP300A Function Generator		Apply sinewave and adjust frequency to 35 ± 0.1 Hz	...	...

3-2. SYSTEM CHECKOUT (CONT)				
Location	Item	Action	Normal Indication	Corrective Action IF indication Abnormal
5. HP3300A Function Generator	...	Adjust amplitude to read 1.000 ± .001 V rms on DMM		
6. DMM	...	Connect DMM between TP5 and TP6 on circuit card A101	DMM shall indicate 1.700 ± 0.62 V rms.	Troubleshoot per para 4-4, Part 2
<b>CALIBRATION CONTROL BANDPASS SIGNAL CHECK</b>				
8. Calibration Control	a. TEST SELECTOR b. FUNCTION GENERATOR B	BANDPASS a. Connect second function generator and adjust frequency to 1.67 f <sub>0</sub> ± 0.5 <KHz	...	...
9. DMM		Connect DMM between TPO and TP1 Adjust amplitude to read 1.414 ± .005 V rms on DMM	...	...
10. HP300A Function Generator	FUNCTION GENERATOR A	a. Set frequency to 20 ± 1 Hz b. Adjust amplitude to read 2 V rms on DMM	... ...	... ...
11. O-scope		a. Connect Channel A between TP4 and TPO (rtn) b. Connect channel B between TP3 and TPO (rtn) c. Set to INPUT SELECTOR to CHOP d. Set channel A to INTERNAL SYNC e. Observe waveform	... ... ... ... (See below)	... ... ... ... Troubleshoot per para 4-4, Part 3

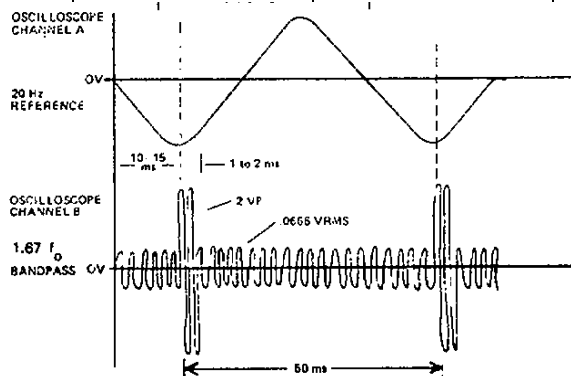

3-2. SYSTEM CHECKOUT (CONT)

Location	Item	Action	Normal Indication	Corrective Action IF indication Abnormal
<b>CALIBRATION CONTROL WIRE SIGNAL CHECK</b>				
12. Calibration Control	a. POWER	a. Off	...	...
...	b. FUNCTION GENERATOR B conductor and shield	b. Connect 20K ohm, 1/4 watt resistor in parallel with 2000 pf capacitor across these points	...	...
...	c. TEST SELECTOR	TSEM WIRE SIG	...	...
...	d. G-BIAS INPUT + and G-BIAS INPUT -	Connect unpowered HP6227B DC power supply between these two jacks, positive-to-positive and negative-to-negative	...	...
...	e. FUNCTION GENERATOR A and FUNCTION GENERATOR B	a. Connect the two HP3300A Function Generators one to A and one to B	...	...
<b>NOTE</b>				
<b>Ensure that the 560 Hz Function Generator is isolated from ground</b>				
...	...	b. Apply 560 ± 1 Hz sinewave to Function Generator B and 870 ± 1 Hz square-wave to Function Generator A	...	...
...	...	c. Adjust the HP3300A Function Generator levels to provide the composite signal shown below Monitor with O-scope at TSEM jack	...	...

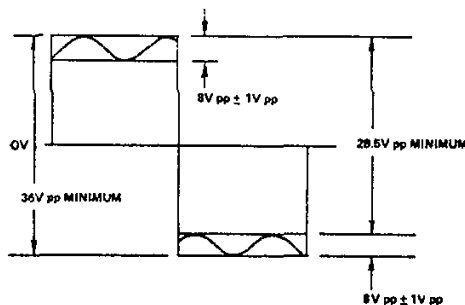

Troubleshoot per para 4-4, Part 4



3-2. SYSTEM CHECKOUT (CONT)				
Location	Item	Action	Normal Indication	Corrective Action IF indication Abnormal
13. Calibration Control	a. TSEM WIRE SIG BIAS b. TSEM WIRE SIG POLARITY	ON + (positive)	... ...	... ...
14. HP6227B DC Power Supply	...	a. Turn on b. Adjust from Of to -6.5V	... ...	... ...
15. O-scope	...	Using DC coupling, check TSEM WIRE SIG OUTPUT signal while adjusting dc Dower supply from 0V to +6.5V	Moves from 0V to +6.5V level on O-scope	Troubleshoot per para 4-4, Part 4
16. Calibration Control	TSEM WIRE SIG POLARITY	- (negative)	...	...
17. O-scope	...	Using DC coupling, check WIRE SIS OUTPUT signal while adjusting dc power supply from 0V to -6.5V	Moves from 0V to -6.5V level on O-scope	Troubleshoot per para 4-4, Part 4
<b>CALIBRATION CONTROL SIGNAL DISTRIBUTION CHECK</b>				
18. Calibration Control	a. POWER b. TEST SELECTOR	OFF +CVAC	... ...	... ...
19. DMM	a. + terminal b. - terminal	Connect to J9-R Connect to J9-G	... ...	... ...
20. P6227B DC Power Supply		Vary output from 0 to +6 volts	DMM tracks power supply output from 0V to 6V	Troubleshoot per para 4-4, Part 5
21. Calibration Control	TEST SELECTOR	-CAC Repeat step 20	... DMM tracks power supply output from 0V to -6V	... Troubleshoot per para 4-4, Part 5
22. Calibration Control	TEST SELECTOR	900 Hz	...	...
23. HP330A Function Generator		a. Connect to FUNCTION GENERATOR A b. Adjust frequency to 900 ± 45 Hz c. Set amplitude to 7 Vrms	... ... ...	... ... ...
24. O-scope		Connect to J9 pin K and the return to J9 pin G	900 Hz Sinewave with 20V P-P amplitude	Troubleshoot per para 4-4, Part 5

3-2. SYSTEM CHECKOUT (CONT)				
Location	Item	Action	Normal Indication	Corrective Action IF indication Abnormal
25. Calibration Control	a. TEST SELECTOR b. TSEM WIRE SIG ON/OFF	a. Off b. OFF	...	...
...	...	c. Disconnect Function Generator	...	...
...	...	d. Disconnect dc power supply	...	...
26. O-scope	a. Channel A b. Channel B	Connect to timer output stop (J5) Connect to timer output start (J4)		
27. Calibration Control	TIME INTERVAL START ON/OFF	ON	...	...
28. O-scope	...	Observe display	Signal goes from logic low to logic high as switch is set to ON (from $0 \pm .5V$ to $9.5 \pm .5V$ )	Troubleshoot per para 4-4, Part 5
29. Calibration Control	TIME INTERVAL STOP ON/OFF	ON	...	...
30. O-scope	...	Observe display	Signal goes from logic low to logic high as switch is set to ON (from $0 \pm$ .5V to $9.5 \pm$ .5V)	Troubleshoot per para 4-4, Part 5
31. ...	...	...	...	Cal kit is now ready for operation per para 3-3.

**3-3. OPERATING INSTRUCTIONS**

The following procedures cover operation of the calibration control. Operation of the TSEM shear pin calibration tester, optical adapter, and unshorting cap are contained in TB9-4935-473-50-1.

INITIAL SETUP

- Equipment Required:
- a. All cal kit equipment listed in paragraph 1-9.
  - b. 115 Vac 60 Hz source.
  - c. TB9-4935-473-50-1
  - d. All accessory equipment listed in TB9-4935-473-50-1.

Location	Item	Action	Remarks
1. Cal Kit	All items	Perform system checkout para 3-2	...
2. Calibration Control	a. POWER	Off	...
	b. TEST SELECTOR	OFF	...
	c. TIME INTERVAL START	OFF	...
	d. TIME INTERVAL STOP	OFF	...
	e. Fan-out cable (CKWI)	Connect between MCU connector and TSGMS MCU	...
f. Ac power cable	Connect to 115 Vac 60 Hz source	...	
g. BNC coax cable	Connect between TSEM WIRE SIG OUTPUT and TSGMS TSEM Signal Monitor Assembly	...	
h. POWER	On	The cal kit is now ready to calibrate the TSGMS as specified in TB9-4935-473-50-1.	

**CHAPTER 4**  
**MAINTENANCE INSTRUCTIONS**  
**FOR**  
**CALIBRATION CONTROL**

Para		Page
4-1	GENERAL.....	4-1
4-2	Tools and Test Equipment.....	4-1
4-3	Preventive Maintenance Checks and Services (PMCS) .....	4-1
4-4	Troubleshooting .....	4-2
4-5	Calibration .....	4-7
4-6	Schematics and Circuit Card A101 Component Location .....	4-7

**4-1. GENERAL**

System checkout paragraph 3-2 is the entry into troubleshooting and calibration requirements. Schematics and circuit card A101 component location are included as an aid to both troubleshooting and calibration. Repair the equipment by replacing the faulty component with a serviceable component.

**4-2. TOOLS AND TEST EQUIPMENT**

No special tools are required to maintain the TSGMS Calibration Kit. A listing of test equipment recommended to checkout and troubleshoot the calibration control is provided in paragraph 3-2, SYSTEM CHECKOUT.

**4-3. PREVENTIVE MAINTENANCE CHECKS AND SERVICES (PMCS)**

Perform calibration per appendix A on a scheduled basis. Unscheduled maintenance actions require performance of the troubleshooting procedure simultaneously with the maintenance action.

4-4. TROUBLESHOOTING							
Perform troubleshooting in conjunction with Para 3-2, SYSTEM CHECKOUT.							
PART 1. POWER CHECK TROUBLESHOOTING							
Test			Indication			Indication Obtained?	
Location	Item	Action	Location	Indicator	Indication	Yes	No
<b>NOTE</b>							
<ul style="list-style-type: none"> <li>• Start with all equipment set up as in Para 3-2 SYSTEM CHECKOUT.</li> <li>• After troubleshooting and repair re-run the applicable checkout checkout procedure.</li> </ul>							
1.	Calibration Control						
	a.	POWER: On	Calibration Control	Lamp	Illuminates	Go to 3-2 System Check-out, Step 2g	Replace power indicator lamp DS1
	b.	Lambda Power Supply: Verify outputs	DMM	Meter	a. $+15 \pm 0.2V$ b. $-15 \pm 0.2V$ c. $+5 \pm 0.1V$	Go to 3-2 System Check-out, step 3	<ol style="list-style-type: none"> <li>1. Check 115 Vac source</li> <li>2. Replace S1</li> <li>3. Adjust Lambda power supply outputs</li> <li>4. Replace Lambda power supply</li> </ol>

4-4. TROUBLESHOOTING (CONT)							
PART 2. 140° PHASE SHIFT TROUBLESHOOTING							
Test			Indication			Indication Obtained?	
Location	Item	Action	Location	Indicator	Indication	Yes	No
<b>NOTE</b>							
Start with all equipment as in Para 3-2 SYSTEM CHECKOUT.							
After troubleshooting and repair re-run the applicable checkout procedure.							
1.	Calibration Control: Connect O-Scope between TP0 and TP6		O-Scope	Screen	35 Hz sinewave 1.0V amplitude	Go to 2	Replace U1
2.	Calibration Control: Connect O-Scope between TF0 and TP5		O-Scope	Screen	35 Hz sinewave 1.0V amplitude 140° from signal at TP6	Go to 3-2 system checkout, step 8	2. Check R1, R2, R23 2 and R24 3. Check C1, VR1 and 2 1. Replace U1 2. Adjust R6 Check R4, R5 and C2

PART 3. BANDPASS SIGNAL TROUBLESHOOTING							
Test			Indication			Indication Obtained?	
Location	Item	Action	Location	Indicator	Indication	Yes	No
<b>NOTE</b>							
Start with all equipment set up as in Para 3-2 SYSTEM CHECKOUT.							
After troubleshooting and repair re-run the applicable checkout checkout procedure.							
1.	O-Scope:		O-Scope	Screen	20 Hz sinewave with 2 Vrms amplitude	Go to 1b	Replace U5
a.	Connect between TPO and TP4						
b.	Connect between TPO and U2 pin 7		O-Scope	Screen	(See below)	Go to 1c	Replace U2
<p>The diagram shows a square wave pulse. The vertical axis is labeled 'OV' and has a 4V scale bar. The horizontal axis has a 50ms scale bar. The pulse width is indicated as 25ms. The signal is a square wave with a period of 50ms.</p>							

4-4. TROUBLESHOOTING (CONT)							
PART 3. BANDPASS SIGNAL TROUBLESHOOTING							
Test			Indication			Indication Obtained?	
Location	Item	Action	Location	Indicator	Indication	Yes	No
	c.	Connect between TPO and U3-A Pin 7	-scope	Screen	(See below)	Go to 1d	Replace U3
	d.	Connect between TPO and U3B pin 10	O-scope	Screen	(See below)	Go to 1e	Replace U3
	e.	Connect between TP0 and TP7	O-Scope	Screen	Same as 1d above	Go to 1f	Replace R13
	f.	Connect between TP0 and TP2	O-Scope	Screen	Sinewave $1.67 f_0$ with $.0666 \pm .0005$ Vrms	Go to 2	1. Replace R 2. Replace R14
	2.	O-Scope: Connect between TPC and TP3	O-Scope	Screen	Sinewave, $1.67 f_0$ with amplitude of $0.638 \pm .0032$ V ms	Go to 4	1. Replace C7 2. Replace R23 3. Replace U5 4. Replace U4

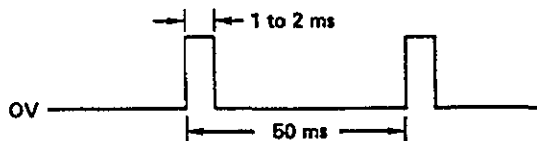
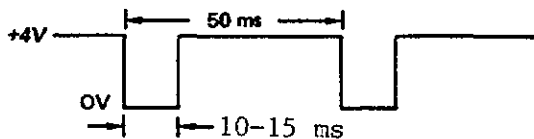

4-4. TROUBLESHOOTING (CONT)							
PART 3. BANDPASS SIGNAL TROUBLESHOOTING (CONT)							
Test			Indication			Indication Obtained?	
Location	Item	Action	Location	Indicator	Indication	Yes	No
	3. Calibration Control:	Connect short jumper wire between TP7 and TP8. Leave O-Scope connected between TP0 and TP3	O-Scope	Screen	Sinewave, $1.67 f_o$ $\pm 0.07$ V rms	Go to 4	Replace U4
	4. Calibration Control:	Remove Jumper wire from TP7 and TP8				Go to 3-2 System Check-out, step 12a	

PART 4. WIRE SIGNAL TROUBLESHOOTING AND CALIBRATION							
Test			Indication			Indication Obtained?	
Location	Item	Action	Location	Indicator	Indication	Yes	No
<b>NOTE</b>							
<b>Start with all equipment setup as in Para 3-2 SYSTEM CHECKOUT.</b>							
<b>After troubleshooting and repair re-run applicable checkout procedure.</b>							
	1. Calibration Control:	Connect O-Scope to transformer T1 input	O-Scope	Screen	870 Hz square-wave and 560 Hz sinewave	Go to 3-2 System Check-out, step 13a	1. Replace R1 2. Replace R2 3. Replace C1 4. Replace T1
	2. O-Scope	a. Using PC coupling check TSEM WIRE SIG output while adjusting HP6227B DC Power Supply from 0V to +6.5V	O-Scope	Screen	Composite signal moves from 0V to +6.5V with the power supply adjustment	Go to 3-2 System Check-out, step 16	1. Replace S2 2. Replace S5 3. Replace S6
		b. Using DC coupler check TSEM WIRE SIG OUTPUT while adjusting HP6227B DC Power Supply from 0V to -6.5V	O-Scope	Screen	Composite signal moves from 0 to -6.5 with the power supply adjustment	Go to 3-2 System Check-out, step 18	1. Replace S2 2. Replace S5 3. Replace S6



4-4. TROUBLESHOOTING (CONT)							
PART 5. SIGNAL DISTRIBUTION TROUBLESHOOTING							
Test			Indication		Indication Obtained?		
Location	Item	Action	Location	Indicator	Indication	Yes	No
<b>NOTE</b>							
<b>Start with all equipment setup as in Para 3-2 SYSTEM CHECKOUT.</b>							
<b>After troubleshooting and repair re-run applicable checkout procedure.</b>							
1.	HP6227B DC Power Supply		DMM	Meter	DMM tracks power output from 0V to +6V	Go to 3-2 System Check-out, step 21	Replace S2
	a. Vary output from 0V to +6V						
	b. Vary output from 0V to -6V		DM	Meter	DMM tracks power supply output from 0V to -6V	Go to 3-2 System Check-out, step 22	Replace S2
2.	Calibration Control: TEST SELECTOR: -CVAC		-CVAC	...	...	...	...
3.	HP6227B DC Power Supply Output: +2		DMM	Meter	+2	Go to 3-2 System Check-out, step 23	
4.	O-Scope		O-Scope	Screen	900 Hz sine-wave with amplitude 20 V P-P	Go to 3-2 System Check-out, step 25	Replace S2
5.	Calibration Control						
	a. TIME INTERVAL START ON/OFF: ON		O-Scope	Screen	Signal goes from logic low to logic high when switch is set to ON	Go to 3-2 System Check-out, step 29	1. Replace U6 2. Replace U6
	b. TIME INTERVAL STOP ON/OFF: ON		O-Scope	Screen	Signal goes From logic low level to a logic high level when switch is set to ON	Go to 3-2 System Check-out, step 31	1. Replace U6 2. Replace U6

**4-5. CALIBRATION**

Perform calibration of the calibration control unit on a scheduled basis. A detailed procedure for calibration of this unit is provided in Appendix A of this manual.

**4-6. SCHEMATICS AND CIRCUIT CARD A101 COMPONENT LOCATION**

The following items have been included as an aid to troubleshooting and calibration:

- Calibration control schematic
- Circuit card A101 schematic
- Lambda power supply schematic
- Calibration control cable schematic
- Circuit card A101 component location

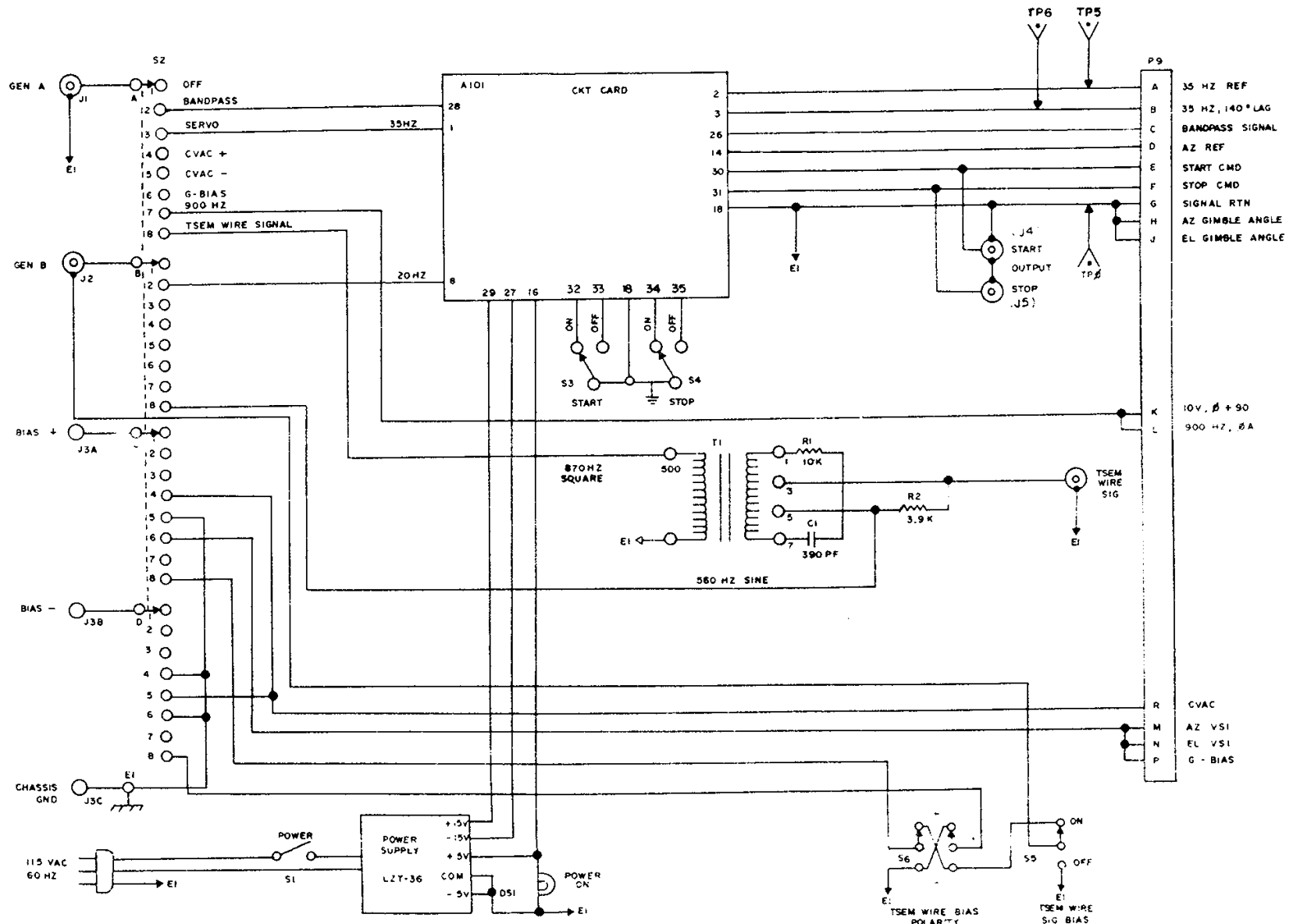

MSC01893

Calibration control schematic.

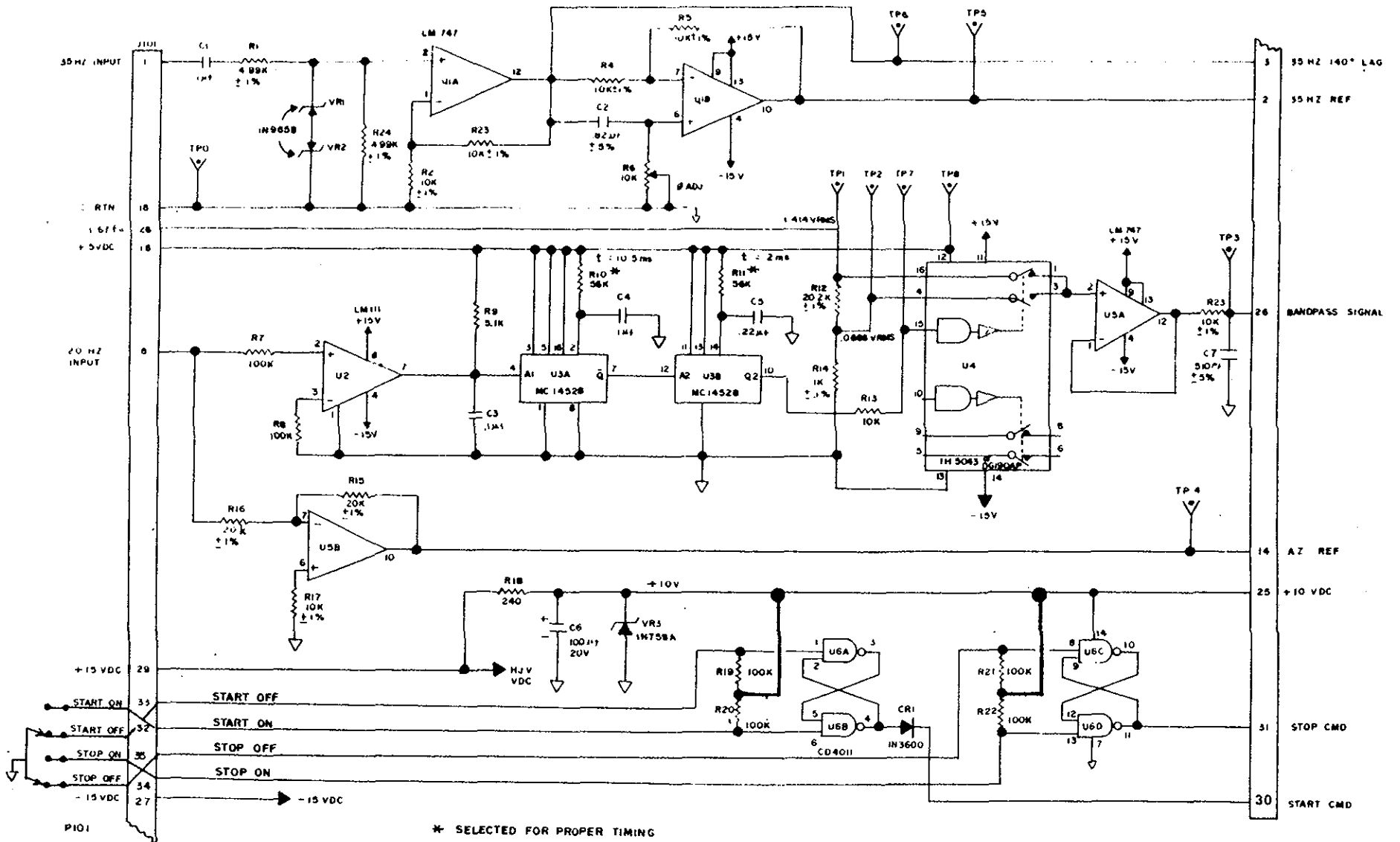

MSC01894

Circuit card A101 schematic.

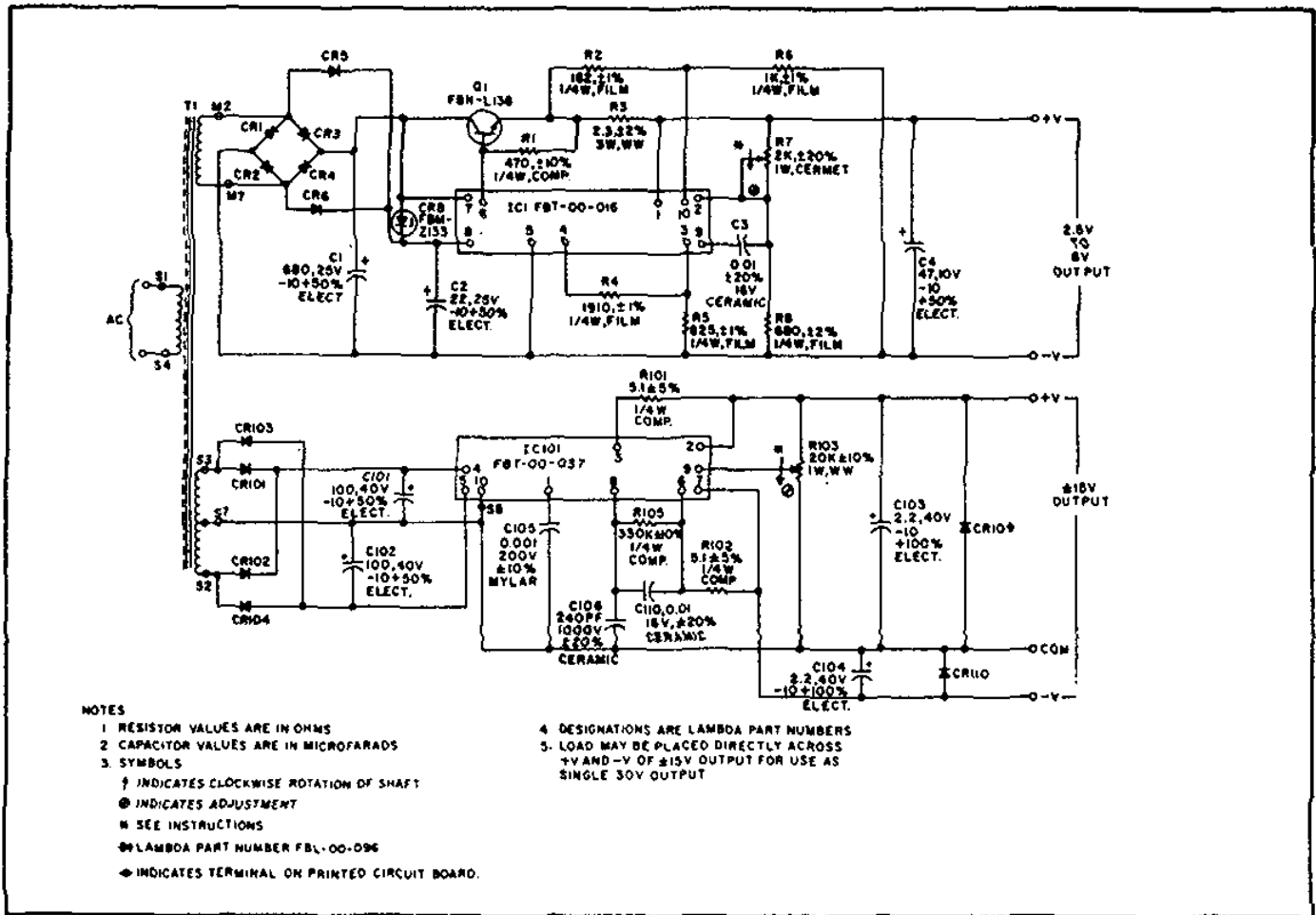

NOTES

- 1 RESISTOR VALUES ARE IN OHMS
- 2 CAPACITOR VALUES ARE IN MICROFARADS
- 3 SYMBOLS
  - ↑ INDICATES CLOCKWISE ROTATION OF SHAFT
  - ⊙ INDICATES ADJUSTMENT
  - ≡ SEE INSTRUCTIONS
  - ⊕ LAMBDA PART NUMBER FBL-00-096
  - ⊖ INDICATES TERMINAL ON PRINTED CIRCUIT BOARD.
- 4 DESIGNATIONS ARE LAMBDA PART NUMBERS
5. LOAD MAY BE PLACED DIRECTLY ACROSS +V AND -V OF  $\pm 15V$  OUTPUT FOR USE AS SINGLE 30V OUTPUT

LAMBDA POWER SUPPLY SCHEMATIC

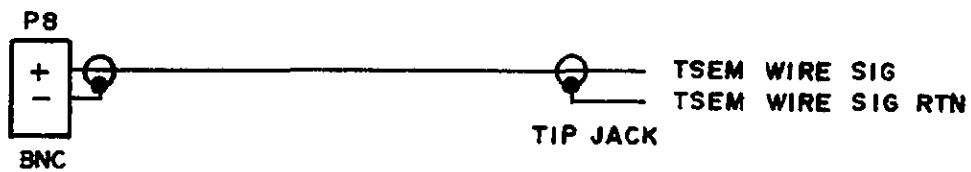
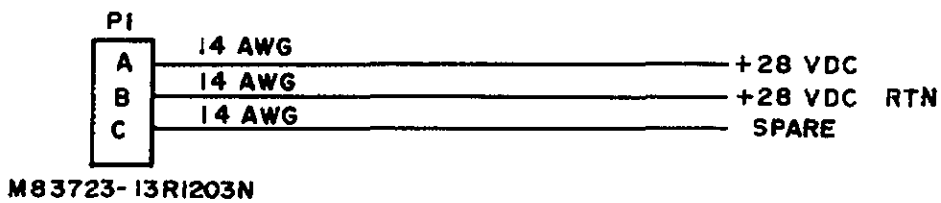
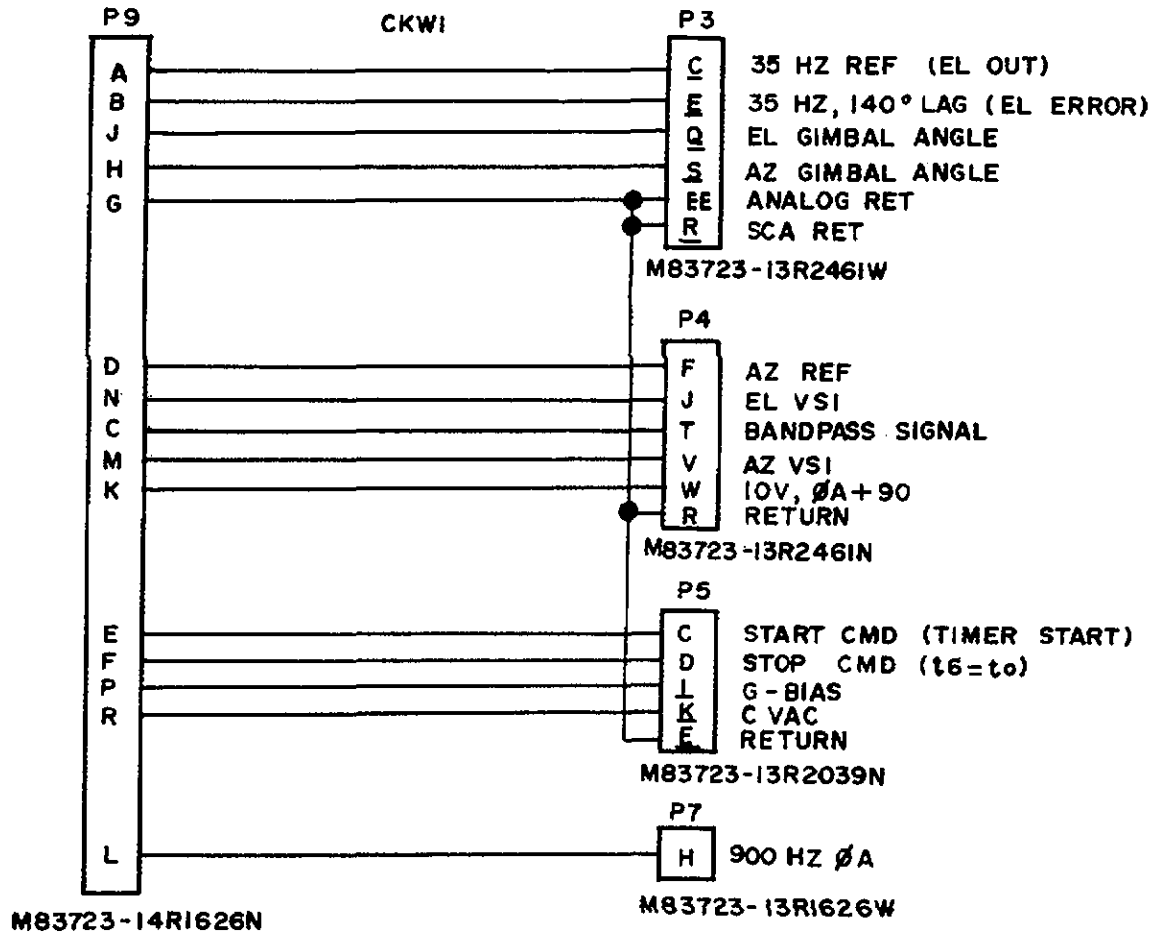

MSC01892

Calibration control cable schematic.

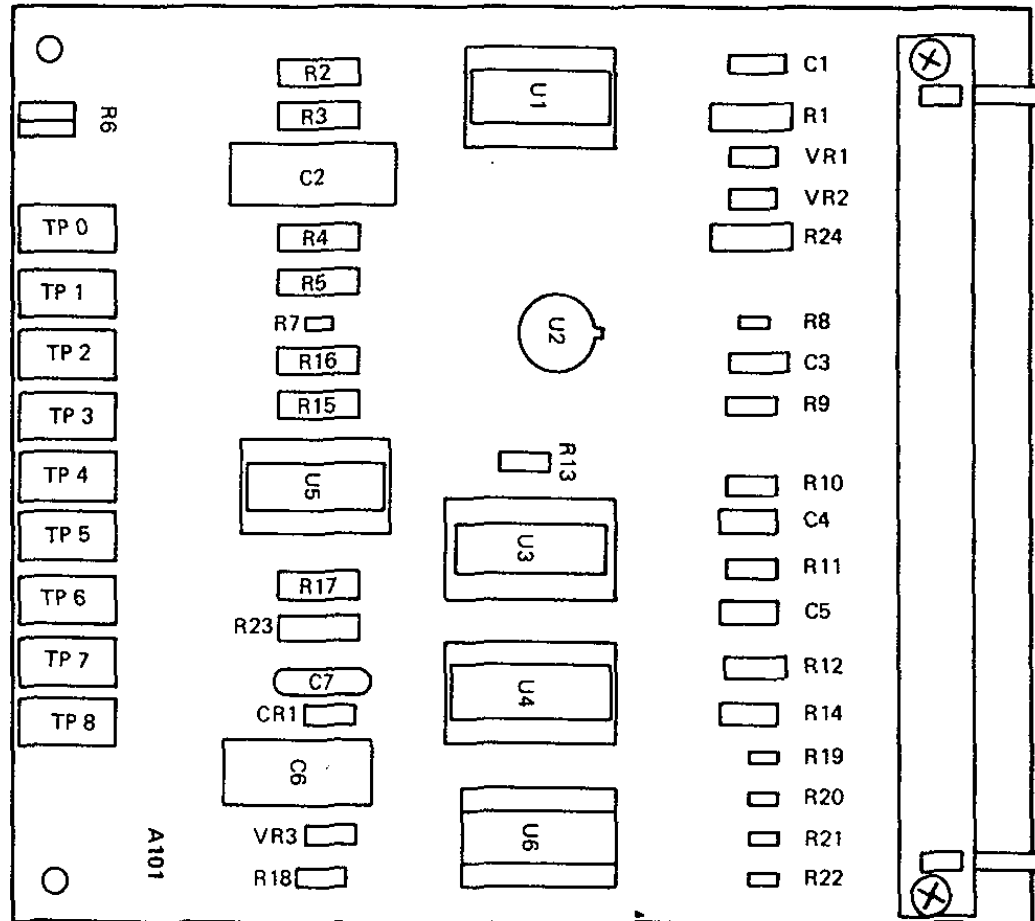

CIRCUIT CARD A101 COMPONENT LOCATION

**CHAPTER 5**  
**MAINTENANCE INSTRUCTIONS**  
**FOR**  
**TSEM SHEAR PIN CALIBRATION TESTER**

<u>Para</u>		<u>Page</u>
5-1	General .....	5-1
5-2	Calibration.....	5-1

**5-1. GENERAL**

The TSEM shear pin calibration tester is repairable only at the factory because of critical dimensions. The only maintenance which should be performed on site are obvious cleaning and calibration.

**5-2. CALIBRATION**

The following calibration procedure is provided in Appendix B:

- CR 2238.10/441 Calibration Requirements Document, Calibration of Trunnion to Plunger Dimensions for TSEM Shear Pin Calibration Tester P/N 1089938-1.



**CHAPTER 6**

**PARTS LIST**

This parts list is organized as follows:

<u>Para</u>		<u>Page</u>
6-1	TSGMS Calibration Kit Parts List .....	6-1
6-2	Circuit Card A101 Parts List .....	6-3
6-3	Lambda Power Supply Parts List .....	6-4

A parts list for the TSEM SHEAR PIN CALIBRATION TESTER has not been given because it is factory repairable only. Manufacturer's part numbers are not given in the Lambda Power Supply parts list because it is a vendor item.

<b>6-1. TSGMS CALIBRATION KIT PARTS LIST</b>				
Reference Designator	Component Description	Quantity	Federal Supply Code	Manufacturer's Part Number
-	Carrying Case	1	98376	X40787
-	TSEM Shear Pin Calibration Tester	1	82577	1089938-1
-	Optical Adapter	1	GFE	7913485
-	Umbilical Unshorting Cap	1	GFE	7913438
-	Calibration Control	1	82577	1090109
A101	Circuit Card (see Para 6-2)	1	06656	64P44-062
C2	Capacitor, 390 pf, 10%, 200V	1	81349	M39014/01-1350
DS1	Lamp Assembly	1	03797	HLD2010
DS1	Lamp, 5V	1	03797	HLD230RT
DS1	Lens	1	03797	25
TBD	BNC Connector	1	81349	M39012/21-0001
TBD	BNC Connector	1	81349	M39012/21-0001
J1	BNC Connector	1	81349	M39012/21-0001
J2	BNC Connector	1	81349	M39012/21-0001
J3A	Banana Jack, Red	1	05276	DF-30-RC
J3B	Banana Jack, Black	1	05276	DF-30-BC
J3C	Banana Jack, Black	1	05276	DF-30-BC
J9	Pin Socket	1	11769	M83723-01R1626N
J101	Connector	1	81349	00-7024-035-163-110
P101	Connector, 35 pin	1	81349	M21097/5-07
P1	Connector, Plug	1	81349	M83723-13R1203N
P3	Connector, Plug	1	81349	M83723-13R2461W
P5	Connector, Plug	1	81349	M83723-13R2039N
P4	Connector, Plug	1	81349	M83723-13R2461N

6-1. TSGMS CALIBRATION KIT PARTS LIST (CONT)				
Reference Designator	Component Description	Quantity	Federal Supply Code	Manufacturer's Part Number
P7	Connector, Plug		81349	M83723-13R1626W
P8	Connector, BNC			
P9	Connector, Plug	1	81349	M83723-14R1626N
-	Connector, Shell	2	81349	M83723-15S-16
-	Connector, Shell	1	81349	M83723-15S-20
-	Connector, Shell	2	81349	M83723-15S-24
-	Power Supply (see Para 6-3)	1	50721	LZT-36
-	Ac Cord	1	70903	BR5358
R1	Resistor 10K, Fixed	1	81349	RCR07G-103JM
R2	Resistor 3.9K, Fixed	1	81349	RCR07G-392JS
S1	Toggle Switch	1	80207	1L1B-2C
S2	Wafer Switch	1	71950	PA1
-	Wafer Switch Assembly	1	71950	PA301
S3	Toggle Switch (SPST)	1	80207	1L1B-2C
S4	Toggle Switch (SPST)	1	80207	1L1B-2C
S5	Toggle Switch (SPST)	1	80207	1L1B-2C
S6	Toggle Switch (DPDT)	1	80207	21B1-1C
T1	Transformer	1	80223	S-15
	Grommet	1	81349	MS35489-4
-	Bracket, Circuit Card Mounting	1	82577	1090108
-	Bracket Power Supply Mounting	1	82577	1090107
-	Panel	1	82577	TBS
-	Screw	2	96904	MS51957-18
-	Nut	2	96906	MS210434
-	Washer	2	80205	NAS620C42
-	Screw	5	80205	NAS1100-C04-4
-	Nut	2	80205	NAS671-C4
-	Screw	2	80205	NAS1635-06-12
-	Washer	2	96906	MS35338-97-4
-	Washer	2	80205	NAS620-C4
-	Washer	2	96906	MS35338-98-6
-	Washer	2	80205	NAS620-C6
-	Screw	4	80205	NAS1635-06-16
-	Nut	2	80205	NAS671-C6
-	Screw	2	80205	NAS1635-06-4
-	Knob	1	90906	MS91528-2F28

6-2. CIRCUIT CARD A101 PARTS LIST				
Reference Designator	Component Description	Quantity	Federal Supply Code	Manufacturer's Part Number
C1 & C4	Capacitor, 1 µf, 10%, 50V	2	81349	M39014/02-1419
C2	Capacitor, 82 µf, 5%, 30V	1	81349	M39022/09-B209M
C3	Capacitor, .1 µf, 10%, 100V	1	81349	M39014/02-1350
C5	Capacitor, .22 µf, 10%, 50V	1	81349	M39014/02-1356
C6	Capacitor, 100 µf, 10%, 20V	1	81349	M39003/01-2301
C9	Capacitor, 510 pf, 5%, 500V	1	TBS	M23269/02-3030
CR1	Diode	1	81349	1N3600-JAN
R1, R24	Resistor, 4.99K, 1/8 watt, 1%	2	81349	RNC60H4991FR
R2, R3,	Resistors 10K, 1/8 watt, 1%	6	81349	RNC60H1002FR
R4, R5,				
R17, R23				
R7, R8	Resistor 100K, 1/4 watt, 5%	6	81349	RCR07G-104JS
R19, R20,				
R21, R22				
R9	Resistor, 5.1K, 1/4 watt, 5%	1	81349	RCR07G-512JS
R10, R11	Resistor, 1/4 watt, 5% (Value Factory Selected)	2	81349	RCR07G-
R12	Resistor 20.2K, .3 watt, 1%	1	18612	5102-20.2K-0.1-PPM
R14	Resistor 1K, .3 watt, 1%	1	18612	5102-1K-0.1-1-PPM
R15, R16	Resistor 20K, 1/8 watt, 1%	2	81349	RNC604-2002FR
R18	Resistor 240, 1/4 watt, 5%	1	81349	RCR07G-241JS
R25	Resistor 10K, 1/4 watt, 5%	1	81349	RCR07G-103JS
TP0	Test Jack, Black	1	49956	TJ255BL
TP1	Test Jack, Brown	1	49956	TJ252BR
TP2	Test Jack, Red	1	49956	TJ253R
TP3	Test Jack, Orange	1	49956	TJ2540R
TP4	Test Jack, Yellow	1	49956	TJ251Y
TP5	Test Jack, Green	1	49956	TJ256GN
TP6	Test Jack, Gray	1	49956	TBS
TP7	Test Jack, Blue	1	49956	TJ257MB
TP8	Test Jack, Violet	1	49956	TBS
U1, U5	IC Op. Amp	2	27014	LM747D
U2	IC Comparator	1	27014	LM111H
U3	Monostable	1	TBS	MC14528AL
U4	IC Switch	1	32293	DG190A
U6	IC Logic	1	86684	CD4011AD
VR1, VR2	Diode-Zener, 15V	2	81349	1N9658-JAN
VR3	Diode-Zener, 10V	1	81349	1N758A-JAN

6-2. CIRCUIT CARD A101 PARTS LIST (CONT)				
Reference Designator	Component Description	Quantity	Federal Supply Code	Manufacturer's Part Number
-	Socket, 8 pin	1	06776	TP5178
-	Socket, 14 pin	2	11769	IC143-W-B-A
-	Socket, 16 pin	3	11769	IC163-W-B-A
-	Terminal Pin	65	30010	K31

6-3. LAMBDA POWER SUPPLY PARTS LIST	
Reference Designator	Component Description
C1	Capacitor, 680 $\mu$ f -10 + 50%, 25V
C2	Capacitor, 22 $\mu$ f -10 + 5%, 25V
C3	Capacitor, 0.01 $\mu$ f $\pm$ 20%, 16V
C4	Capacitor, 47 $\mu$ f -10 + 50%, 10V
C101	Capacitor, 100 $\mu$ f -10 + 50%, 40V
C102	Capacitor, 100 $\mu$ f -10 + 50%, 40V
C103	Capacitor, 2.2 $\mu$ f -10 + 100%, 43V
C104	Capacitor, 2.2 $\mu$ f - 10 + 100%, 40V
C105	Capacitor, 0.001 $\mu$ f $\pm$ 10%, 200V
C106	Capacitor, 240 $\mu$ f $\pm$ 20%, 1000V
C110	Capacitor, 0.01 $\mu$ f $\pm$ 20%, 16V
CR1, CR2, CR3, CR4, CR5, CR6, CR8, CR101, CR102, CR103, CR104, CR109, CR110	} Diodes
IC1	Integrated Circuit
IC101	Integrated Circuit
R1	Resistor, 470 ohms, 1/4 watt $\pm$ 10%
R2	Resistor, 182 ohms. 1/4 watt $\pm$ 1%
R3	Resistor 2.3 ohms, 3 watt $\pm$ 2%
R4	Resistor 1910 ohms, 1/4 watt $\pm$ 1%
R5	Resistor 825 ohms, 1/4 watt, $\pm$ 1%
R6	Resistor 1K ohms, 1/4 watt $\pm$ 1%
R7	Potentiometer, 2K, 1 watt $\pm$ 20%
R8	Resistor 825 ohms, 1/4 watt $\pm$ 1%
R101	Resistor 5.1 ohms, 1/4 watt $\pm$ 5%

6-3. LAMBDA POWER SUPPLY PARTS LIST	
Reference Designator	Component Description
R102	Resistor 5.1 ohms, 1/4 watt, ±5%
R103	Potentiometer 20K, 1 watt ±10%
R105	Resistor 330K, 1/4 watt, ±10%
T1	Transformer

APPENDIX A

---

CALIBRATION PROCEDURE FOR  
 CALIBRATION CONTROL (HAC P/N 1090109)  
 AS PART OF TSGMS CALIBRATION KIT  
 HUGHES AIRCRAFT COMPANY P/N 1089933

---

Headquarters, Department of the Army, Washington, D.C.

---

<u>Para</u>	<u>Page</u>	<u>Para</u>	<u>Page</u>		
Section I.	IDENTIFICATION AND DESCRIPTION .....	A-2	Section III. PRELIMINARY OPERATIONS .....	A-6	
1	Test Instrument Identification .....	A-2	6	Preliminary Instructions .....	
2	Calibration Data Card, .....	A-2	7	Calibration Control Set Up .....	A-6
	DA Form 2416 .....	A-2	Section IV. CALIBRATION PROCESS.....	A-6	
3	Calibration Description .....	A-2	8	TI Calibration Control .....	A-6
Section II.	EQUIPMENT REQUIREMENTS .....	A-3			
4	Equipment Required .....	A-3			
5	Accessories Required .....	A-3			

**SECTION I. IDENTIFICATION AND DESCRIPTION**

**1. TEST INSTRUMENT IDENTIFICATION**

This document provides instruction for the calibration of the Calibration Control P/N 1090109 as part of the TSGMS Calibration Kit P/N 1089933. The calibration control will be referred to as the TI (test instrument) throughout this document.

Model Variations. This document applies to Hughes Aircraft Company MICOM production models only.

**2. CALIBRATION DATA CARD, DA FORM 2416**

- a. Forms, records, and reports required for calibration personnel at all levels are prescribed in TM 38-750. DA Form 2416 must be annotated in accordance with TM 38-750 for each calibration performed.
- b. Adjustments are provided at the end of each section.

**3. CALIBRATION DESCRIPTION**

TI parameters and performance specifications which pertain to this calibration are listed in table 1.

TABLE 1. CALIBRATION DESCRIPTION

Test Instrument Parameters	Performance Specifications
Line Voltage regulation. <sup>1</sup>	Satisfactory performance with any line voltage between 105.0 and 132.0 vac, with frequency 57.0 to 63.0 Hz.
Bandpass Signal Amplitude.	±2.00 v pk for peak signal amplitude. ±94.27 mV pk for noise signal amplitude. Peak signal to rms noise ratio = 30:1. Accuracy: ±1% for signal-to-noise ratio
Bandpass Signal timing.	Reference signal frequency 20.0 Hz (50.0 milliseconds) ±1% peak S/N ratio, PRF: 50 ± 0.5 milliseconds. Pulse width: 1 to 2 milliseconds
Servo Signal Phase Shift.	Reference Frequency: 35.0 Hz ±1%. Phase Shift lags reference by 140.0 ± 1°.
<sup>1</sup> This specification is for information only and is not necessarily verified in this procedure.	

**SECTION II. EQUIPMENT REQUIREMENTS**

**4. EQUIPMENT REQUIRED**

Table 2-1 identifies the specific equipment used in the calibration procedure. This equipment is issued with the secondary reference calibration standards set and is to be used in performing this procedure. Alternate items may be used by the calibrating activity when the equipment listed in table 2-1 is not available. The items selected must be verified to perform satisfactorily prior to use and must bear evidence of current calibration. The equipment must meet or exceed the minimum use specifications listed in table 2-1. The accuracies in table 2-1 provide a four-to-one accuracy ratio between the standard and TI. Where the four-to-one accuracy ratio cannot be met, the actual accuracy of the equipment selected is shown in parenthesis.

**5. ACCESSORIES REQUIRED**

The accessories listed in table 2-2 are issued with the secondary reference calibration standards set and are to be used in this calibration procedure. When necessary, these items may be substituted by equivalent items unless specifically prohibited.

TABLE 2-1. MINIMUM SPECIFICATIONS OF EQUIPMENT REQUIRED.

Item	Common Name	Minimum Use Specifications	Manufacturer, Model and Part Number
A1	SIGNAL GENERATOR	Range: 20.0 to 6000.0 Hz Accuracy: $\pm 2\%$ of setting. Amplitude: 0.0 to 10.0 V rms.	Krohn-Hite, Model 4100AR-8 (7915951); Wavetek, Model 145 (7915944)
A2	DIFFERENTIAL VOLTMETER	Range: 0.0 to 10.0 V dc Accuracy: $\pm 0.09\%$ of reading Range: 0.0 to 2.5 V rms. Accuracy: $\pm 0.9\%$ of reading Frequency: 20.0 to 6000.0 Hz	John Fluke, Model 887( ) Differential Voltmeter
A3	FREQUENCY COUNTER W/TIME INTERVAL PLUG-IN	Range: 20.0 to 6000.0 Hz Accuracy: $\pm 0.06\%$ of indication $\pm 1$ count Range: 30.0 to 60.0 milliseconds Accuracy: $\pm 0.06\%$ of indication $\pm 1$ count Time Base: Frequency: 1 MHz. Aging Rate: <3 parts in $10^7$ /week	Hewlett-Packard, Model 5345A measurement system (MIS-28754)
A4	AC VOLTAGE CALIBRATOR	Range: 1.00000 to 10.99999 V rms Accuracy: $\pm 0.09\%$ of setting Frequency: 50 Hz to 20.0 KHz Accuracy: $\pm 2.5\%$ of setting	Hewlett Packard, Model C90-745A-C90 (MIS10342TYPE1)
A5	OSCILLOSCOPE W/AMPLIFIER PLUS-IN, TIME BASE PLUG-IN	Range: 0.0 to 36.0 V pk Accuracy: $\pm 3\%$ of Indication Bandpass: 10.0 MHz Risettime: 35 nsec. Sweep Accuracy: $\pm 5\%$ of Indication Delay Accuracy: $\pm 1\%$ of reading	Tektronix, Type 5440 with 5B42 and 5A13N (MIS-28706)
A6	PHASE ANGLE STANDARD	Range: 140.0° Accuracy: $\pm 0.5^\circ$ Frequency: 30.0 to 70.0 Hz	Dytronics, Model 311 RT1 and 717 (MIS10271)



TABLE 2-2. ACCESSORIES REQUIRED

Item	Common Name.	Description and Part Number.
B1	CABLE <sup>2</sup>	Cable Assy., RF, BNC to BNC. 30-in lg. (7907467).
B2	CONNECTOR <sup>1</sup>	Plug, electrical, BNC jack to double banana plug (black)(7907592).
B3	ADAPTER	Connector, T shape, 1 male contact, 2 female contacts (MS35173-274C).
B4	ADAPTER <sup>3</sup>	Prod, Test, Pin plug to banana jack (10394564-010).
B5	ELECTRICAL LEAD <sup>2</sup>	24-in., single banana plug to single banana plug (red)(7907497).
B6	ELECTRICAL LEAD <sup>1</sup>	24-in., single banana plug to single banana plug (black)(7907498).
B7	ADAPTER <sup>1</sup>	Banana jack to pin plug 215 (red) (7907517).
B8	ADAPTER <sup>1</sup>	Banana jack to pin plug 215 (black) (7907528).
B9	CABLE ASSEMBLY <sup>1</sup>	Radio Frequency, BNC to 2 alligator clips 36 in. lg. (ALCBNC36) (7909410).
B10	ELECTRICAL LEAD	4-in., single banana plug to single banana plug (7907491).

<sup>1</sup>Two required.  
<sup>2</sup>Three required.  
<sup>3</sup>Four required.

### SECTION III. PRELIMINARY OPERATIONS

#### 6. PRELIMINARY INSTRUCTIONS

- a. The instructions outlined in this section are preparatory to the calibration process. Personnel should become familiar with the entire document before beginning the calibration.
- b. Items of equipment used in this procedure are referenced within the text by common name and identification number as listed in tables 2-1 and 2-2. For the identification of equipment referenced by item numbers prefixed with A, see table 2-1 and for prefix B, see table 2-2.

#### WARNING

**HIGH VOLTAGE is present during the performance of this calibration. DEATH ON CONTACT may result if personnel fail to observe safety precautions.**

#### 7. CALIBRATION CONTROL SETUP

- a. Remove TI from protective cover.
- b. Position TI controls as follows:
  - START/OFF switch to OFF
  - STOP/OFF switch to OFF
  - TEST SELECTOR to OFF
  - POWER switch to OFF.
- c. Connect TI ac power cable to 115 VAC, 60 Hz and set TI POWER switch to ON.
- d. Install dual trace amplifier and time base plug-in into oscilloscope (A6). Energize oscilloscope.

### SECTION IV. CALIBRATION PROCESS

#### NOTE

**Unless otherwise specified, verify the results of each test and take corrective action by performing para 3-2, SYSTEM CHECKOUT, whenever the test requirement is not met before continuing with the calibration.**

#### 8. TI SIGNAL PROCESSOR

- a. Performance Check
  - (1) Connect ac voltage calibrator (A4) to TI FUNCTION GENERATOR "A" with cable (B1) and connector (B2). Set TI TEST SELECTOR to BANDPASS.
  - (2) Adjust ac voltage calibrator controls for 6.0 kHz and 1.4142 V rms.
  - (3) Connect differential voltmeter (A2) to TI A101 TP-0 (Lo/Black) and A101 TP-2 (Hi). The differential voltmeter must indicate between 0.0662 and 0.0672 V rms.
  - (4) Connect TI A101 TP-7 to A101 TP-8 with electrical lead (B10) and two adapters (B7).
  - (5) Disconnect differential voltmeter at A101 TP-2 and connect to A101 TP-3 (Hi). The differential voltmeter must indicate between 1.310 and 1.450 V rms.
  - (6) Disconnect jumper at TI A101 TP-7 and TP-8. The differential voltmeter must indicate between 0.0620 and 0.0667 V rms.

- (7) Disconnect electrical leads. Connect equipment as shown in figure A-1.
- (8) Adjust ac voltage calibrator (A4) FREQUENCY controls for 1.67  $\zeta$  and output voltage controls for 1.4142 V rms.
- (9) Position signal generator (A1) frequency controls for 20 Hz and adjust AMPLITUDE control for a differential voltmeter (A2) indication between 1.9 and 2.1 V rms. Disconnect differential voltmeter.
- (10) Connect frequency counter (A3) to TI FUNCTION GENERATOR "B" and adapter (B3). Adjust signal generator frequency controls for a frequency counter indication between 49.9 and 50.1 milliseconds.
- (11) SET OSCILLOSCOPE (A5) channels "A" and "B" to dc coupled and connect channel "A" to TI TP-4. Connect channel "B" to TI TP-3. Connect oscilloscope common to TI TP-O. Connect EXT TRIG on oscilloscope to TI FUNCTION GENERATOR "B". Adjust oscilloscope controls to display the bandpass signal as shown in figure A-2.
- (12) WITH OSCILLOSCOPE CH 1 and CH 2 POSITION controls verify that negative peaks of CH 1 display is coincident with negative peaks of CH 2 display.
- (13) Utilizing oscilloscope TIME/DIV controls measure the interval between start of sweep and leading edge of first bandpass signal pulse. Oscilloscope must indicate between 10.0 and 15.0 milliseconds.
- (14) Utilizing oscilloscope DLY'D SWP function and DELAY TIME control, measure width of the positive portion of bandpass signal pulse. Oscilloscope indication must be between 1.0 and 2.0 milliseconds.
- (15) Utilizing oscilloscope DLY'D SWP function and DELAY TIME control, measure the time interval between leading edge of first bandpass signal pulse and second bandpass signal pulse. Oscilloscope indication must be between 49.5 and 50.5 milliseconds.
- (16) Connect oscilloscope A input to START connector and B input to STOP connector.
- (17) On the TI set the START switch to ON. The oscilloscope A input signal will go from a logic low to a logic high as the switch is set to ON (from 0  $\pm$ 0.5 V to 9.5  $\pm$ 0.5 V).
- (18) On the TI set the STOP switch to ON. The oscilloscope B input signal will go from a logic low to a logic high as the switch is set to ON. (from 0  $\pm$ 0.5 V to 9.5  $\pm$ 0.5 V).

#### NOTE

**The SERVO position of the TEST SELECTOR switch may not be required in TB 9-4935-473-50-1 or its future revisions when used to calibrate Test Set, Guided Missile System II 499000 (TOW AIRBORNE SYSTEM). In this case, paragraphs (19) through (22) below may be omitted.**

- (19) Connect equipment as shown in figure A-3.
- (20) Connect differential voltmeter (A2) to TI A101 TP-0 (LO/Black) and A101 TP-5 (Hi).

- (21) Set TI TEST SELECTOR to SERVO. Adjust signal generator (A1) controls for an differential voltmeter indication between 0.95 and 1.05 V rms and a frequency counter indication between 28.29 and 28.86 milliseconds.
- (22) Measure the phase difference between the signals at TI J9 pin B and J9 pin A. If indicated phase difference is not between 139.0 and 141.0 degrees, perform b below.
- b. Adjustments. Adjust TI A101 R6 for an indicated phase difference of  $140 \pm 0.5$  degrees.

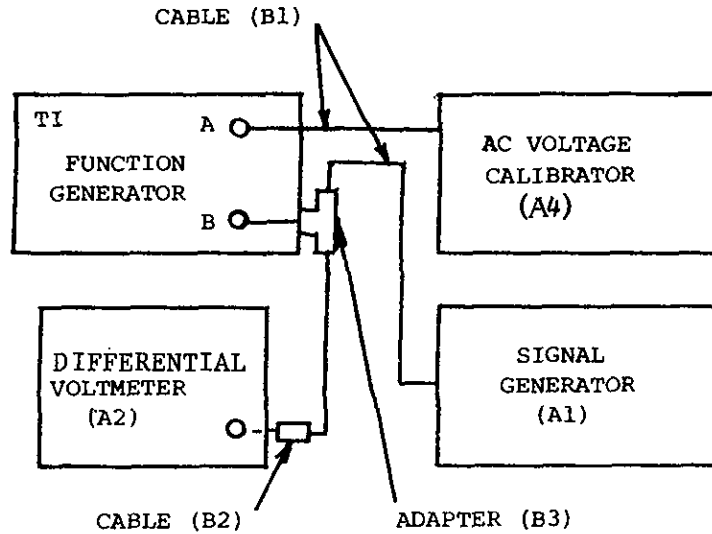

Figure A-1. Bandpass Signal Setup.

c. Calibration Control Final Procedure

- (1) De-energize and disconnect all equipment.
- (2) Annotate and affix DA label 80 (US Army Calibration System). When the TI cannot be adjusted within tolerances, annotate and affix DA Form 2417 (Unserviceable Limited Use tag).

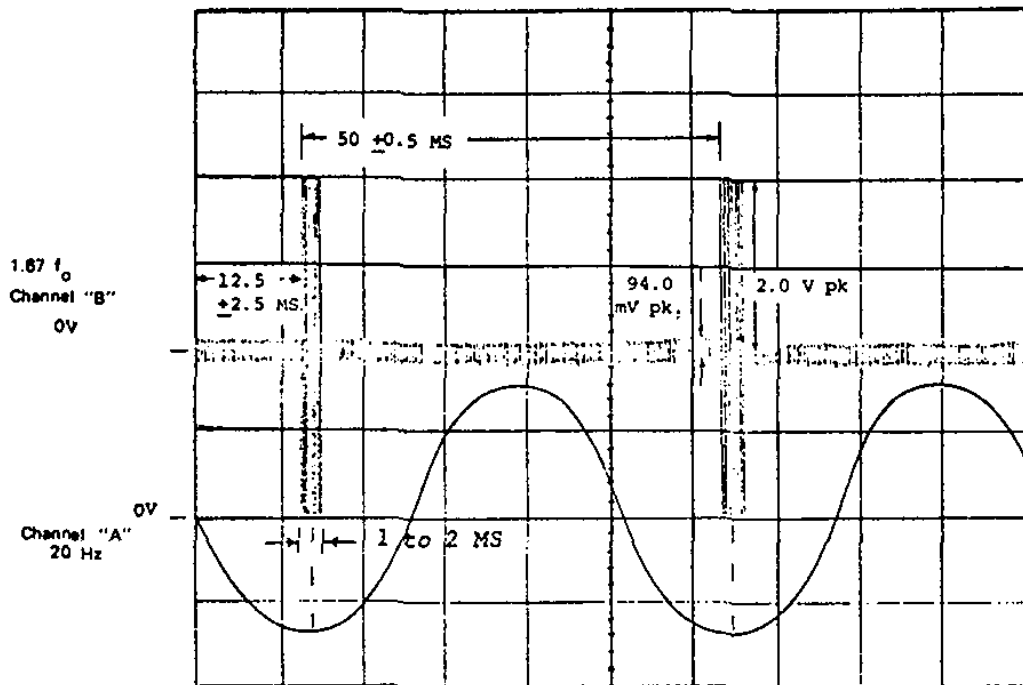

Figure A-2. Bandpass Signal

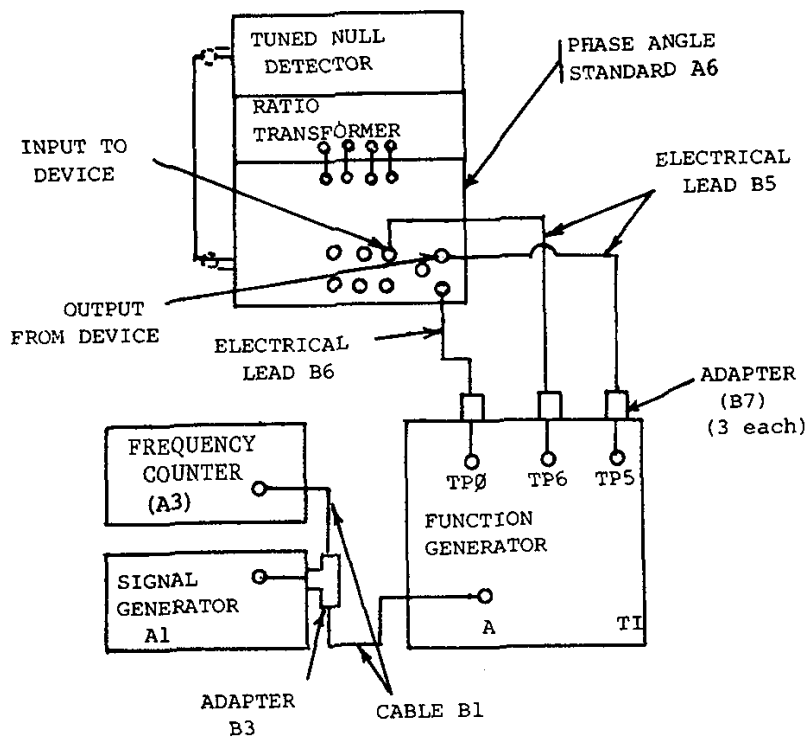

Figure A-3. Servo Signal Phase Setup

**APPENDIX B**

CALIBRATION PROCEDURE FOR

TSEM SHEAR PIN CALIBRATION

TESTER, APN 7915858

HUGHES AIRCRAFT COMPANY P/N 1089938-1

Headquarters, Department of the Army, Washington, DC

<u>Para</u>		<u>Page</u>
Section I.	IDENTIFICATION AND DESCRIPTION .....	B-1
1	Test Instrument Identification .....	B-1
2	Calibration Data Card, DA Form 2416 .....	B-1
3	Calibration Description .....	B-1
Section II.	EQUIPMENT REQUIREMENTS	
4	Equipment Required .....	B-2
5	Accessories Required .....	B-2
Section III.	CALIBRATION PROCESS	
6	Preliminary Instructions .....	B-4
7	Equipment Setup .....	B-4
8	TI Calibration .....	B-6
9	Final Procedure .....	B-7

**SECTION I. IDENTIFICATION AND DESCRIPTION**

**1. TEST INSTRUMENT IDENTIFICATION**

This document provides Instruction for the calibration of TSEM Shear Pin Calibration Tester, part of the TSGMS Calibration Kit P/N 1089933. The TSM Shearpin Calibration Tester will be referred to as the TI (test instrument) throughout this document.

**2. CALIBRATION DATA CARD, DA FORM 2416**

- a. Forms, records, and reports required for calibration personnel at all levels are prescribed in TM 38-750. DA Form 2416 must be annotated in accordance with TM 38-750 for each calibration performed.
- b. Adjustments are provided at the end of each section.

**3. CALIBRATION DESCRIPTION**

TI parameters and performance specifications which pertain to this calibration are listed in table 1.

TABLE 1. CALIBRATION DESCRIPTION

Test instrument parameters	Performance specifications
Distance between simulated holdback pin and trunnion interface	
Upper limit position	Range: 2.254 in. Accuracy: ±0.001 in.
Lower limit position	Range: 2.241 in. Accuracy: ±0.001 in.

**SECTION II. EQUIPMENT REQUIREMENTS**

**4. EQUIPMENT REQUIRED**

Table 2-1 identifies the specific equipment used in the calibration procedure. This equipment is issued with the secondary reference calibration standards set and is to be used in performing this procedure. Alternate items may be used by the calibrating activity when the equipment listed in table 2-1 is not available. The items selected must be verified to perform satisfactorily prior to use and must bear evidence of current calibration. The equipment must meet or exceed the minimum use specifications listed in table 2-1. The accuracies in table 2-1 provide a four-to-one ratio between the standard and TI.

**5. ACCESSORIES REQUIRED**

The accessories listed in table 2-2 are issued with the secondary reference calibration standards set and are to be used in this calibration procedure. When necessary, these items may be substituted by equivalent items unless specifically prohibited.

<i>TABLE 2-1. MINIMUM SPECIFICATIONS OF EQUIPMENT REQUIRED</i>			
<b>Item</b>	<b>Common name</b>	<b>Minimum use specifications</b>	<b>Manufacturer and model (part number)</b>
A1	ANGLE PLATE	Dimensions: 4-1/2 W x 5 L x 8H	GGG-P-441A (p/o 7915875)
A2	ANGLE PLATE	Dimensions: 3-3/4 W x 4 L x 5H	GGG-P-441A (p/o 7915875)
A3	ELECTRICAL HEIGHT GAGE	Capability to check parallelism at 13 in.	FED 2400 (7904823)
A4	GAGE BLOCK SET	Range: 81 pieces, 0.050 to 4.000 in. Accuracy: Grade 2	(7901765)
A5	GAGE BLOCK SET	Range: 8 pieces, 5.000 to 20.000 in. Accuracy: Grade 2	(7901363)
A6	SURFACE PLATE	Size: 18 x 24 in. Accuracy: Class 1, Grade A	(7900123)

<i>TABLE 2-2. ACCESSORIES REQUIRED</i>		
<b>Item</b>	<b>Common name</b>	<b>Description (part number)</b>
B1	LEAD SHOT	Two 13.5 ±0.1 lb. bags. 9030K1 (p/o 7915875)
B2	SURFACE GAGE	(7901950)
B3	TORQUE WRENCH	0-10 in. lbs (furnished by TI owner)



**SECTION III. CALIBRATION PROCESS****6. PRELIMINARY INSTRUCTIONS**

- a. The instructions outlined in this section are preparatory to the calibration process. Personnel should become familiar with the entire document before beginning the calibration.
- b. Items of equipment used in this procedure are referenced within the text by common name and identification number as listed in table 2-1 and 2-2. For the identification of equipment referenced by item numbers prefixed with A, see table 2-1 and for prefix B, see table 2-2.

**7. EQUIPMENT SETUP**

- a. Prepare two 13.5  $\pm$ 0.1 lb. bags of lead shot (B1), and tie a loop at the top of each bag to permit hanging from each trunnion as shown in figure B-1.
- b. Make up two stacks of gage blocks, 13.100 and 10.900 inches, from gage block sets (A4 and A5).
- c. Set up equipment as shown in figure B-1 and allow to stabilize for at least 12 hours.

**NOTE**

**TI depressor contact is balanced on upper surface of angle plate (A2).**

- d. Remove T pin (fig. B-1) and rotate TI depressor arm to upper limit (2.254 in.) position. Replace and secure T pin.
- e. Check parallelism from top planes of trunnions (fig. B-1) to surface plate (A6), using electrical height gage (A3). If parallelism is not within  $\pm$ 0.0002 inches, perform (1) through (3) below:
  - (1) Determine the low side trunnion, using electrical height gage.
  - (2) Position surface gage (B2) pointer under low side trunnion and, using adjustment on base, raise low side trunnion to adjust for parallelism.
  - (3) Repeat (1) and (2) above until parallelism is within  $\pm$ 0.0002 inches. Do not remove or adjust surface gage after parallelism is obtained.

**NOTE**

**Lead shot bags (B1) must remain on trunnions throughout entire calibration.**

NOTE: PUSH TRUNNIONS TO THEIR INNERMOST POSITION BEFORE HANGING LEAD SHOT BAGS.

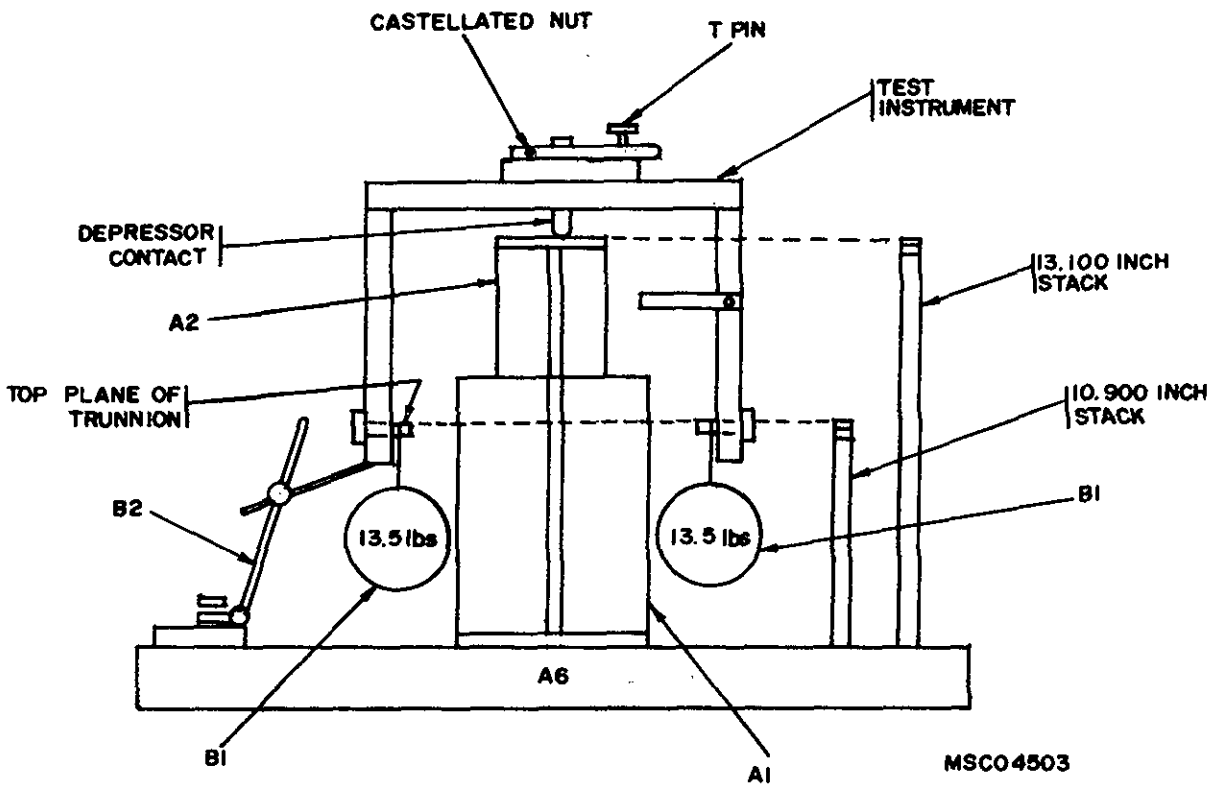

Figure B-1. Equipment setup.

**8. TI CALIBRATION****a. Performance Check**

- (1) Measure distance from surface plate (A6) to top plane of trunnion, using electrical height gage (A3) and smaller stack. Record value.

**NOTE**

**Add or remove gage blocks as required until stack is the same height as top plane of trunnion.**

- (2) Repeat (1) above for a total of three times. Record average value.
- (3) Measure distance from surface plate to top surface of angle plate (A2), using electrical height gage and taller stack. Make measurement within 1 inch of depressor contact. Record value.
- (4) Repeat (3) above for a total of three times. Record average value.
- (5) Subtract overage value recorded in (2) above from average value recorded in (4) above. If the difference is not between 2.253 and 2.255 inches, perform b below. Record value.
- (6) Remove T pin and rotate TI depressor arm to lower limit (2.241) position. Replace and secure T pin.
- (7) Repeat 7e and (1) through (5) above. If the difference in (5) above is not between 2.240 and 2.242 inches, perform b(2) through (7) below. Record value.

**b. Adjustments**

- (1) Perform a(6) and (7) above.
- (2) Subtract value recorded in a(7) from value recorded in a(5). If this value (travel range) is between 0.01 10 and 0.0150 inches, perform adjustments in (3) through (7) below. If travel range is not within limits, no adjustments can be made.
- (3) Determine a value that will bring both values within tolerance, and make up a gage block stack equal to the value.
- (4) Remove cotter pin from castellated nut (fig. B-1) and loosen nut.
- (5) Adjust setscrew to value determined in (3) above.
- (6) Tighten castellated nut to 5-8 in. lb, using torque wrench (B3) and replace cotter pin.
- (7) Repeat paragraph 7e and a(1) through (7) above.

**NOTE**

**Parallelism must be rechecked in 7e especially if surface gage (B2) was used.**

**9. FINAL PROCEDURE**

- a. Disconnect all equipment.
- b. When all parameters are within tolerance, annotate and affix DA Label 80 (US Army Calibrated Instrument). When the TI receives limited or special calibration, annotate and affix DA Label 163 (US Army Limited or Special Calibration). When the TI cannot be adjusted within tolerance, repair the TI in accordance with the maintenance manual. When repair is delayed for any reason or the TI cannot be repaired with local resources, annotate and affix DA Form 2417 (US Army Calibration System Rejected Instrument) and inform the owner/user accordingly in accordance with TB 750-25-1.

**APPENDIX C**  
**REFERENCES**

---

Following is a list of publications available to TSGMS operator and maintenance personnel:

DA Pam 310-1	Consolidated Index of Army Publication and Blank Forms
SB 38-100	Preservation, Packaging, Packing, and Marking Materials, Supplies, and Equipment used by the Army
TB 43-0118	Field Instruction for Painting and Preserving Electronic Equipment
TB 43-180	Calibration Requirements for the Maintenance of Army Materiel
TM 38-750	The Army Maintenance Management System (TAMMS)
TM 740-90-1	Administrative Storage of Equipment

**APPENDIX D**  
**BASIC ISSUE ITEMS LIST**

---

(A listing of Basic Issue Items is not applicable to this publication.)

## APPENDIX E

MAINTENANCE ALLOCATION CHART (MAC)

---

**E-1. General**

This appendix provides a summary of the maintenance operations covered in the equipment literature. It authorizes categories of maintenance for specific maintenance functions on repairable items and components and the tools and equipment required to perform each function. This appendix may be used as an aid in planning maintenance operations.

**E-2. Maintenance Functions**

Maintenance Functions will be limited to and defined as follows:

*a. Inspect.* To determine the serviceability of an item by comparing its physical mechanical, and/or electrical characteristics with established standards through examination.

*b. Test.* To verify serviceability and to detect incipient failure by measuring the mechanical or electrical characteristics of an item and comparing those characteristics with prescribed standards.

*c. Service.* Operations required periodically to keep an item in proper operating condition, i.e., to clean (decontaminate), to preserve, to drain, to paint, or to replenish fuel, lubricants, hydraulic fluids, or compressed air supplies.

*d. Adjust.* Maintain within prescribed limits by bringing into proper or exact position, or by setting the operating characteristics to the specified parameters.

*e. Align.* To adjust specified variable elements of an item to about optimum or desired performance.

*f. Calibrate.* To determine necessary corrections and cause corrections to be made on, or to adjust, instruments or test measuring and diagnostic equipment used in precision measurement. Consists of the comparison of two instruments, one of which is a certified standard of known accuracy, to detect and adjust any discrepancy in the accuracy of the instrument being compared.

*g. Install.* The act of emplacing, seating, or fixing into position an item, part, or module (component or assembly) in a manner to allow the proper functioning of an equipment or system.

*h. Replace.* The act of substituting a serviceable like part, subassembly, or module (component or assembly) for an unserviceable counterpart.

*i. Repair.* The application of maintenance services (inspect, test, service, adjust, align, calibrate, replace) or other maintenance actions (welding, grinding, riveting, straightening, facing, remachining, or resurfacing) to restore serviceability to an item by correcting specific damage, fault, malfunction, or failure in a part, subassembly, module/component/assembly, end item or system.

*j. Overhaul.* That maintenance effort (service/action) necessary to restore an item to a completely serviceable/operational condition as prescribed by maintenance standards (e.g., DMWR) in appropriate technical publications. Overhaul is normally the highest degree of maintenance performed by the Army. Overhaul does not normally return an item to like-new condition.

*k. Rebuild.* Consists of those services/actions necessary for the restoration of unserviceable equipment to a like-new condition in accordance with original manufacturing standards. Rebuild is the highest degree of materiel maintenance applied to Army equipment. The rebuild operation includes the act of returning to zero those age measurements (hours, miles, etc.) considered in classifying Army equipment/components.

### **E-3. Explanation of Format**

*a. Group Number.* Column 1 lists group numbers, whose purpose is to match components, assemblies, subassemblies, and modules with the next higher assembly.

*b. Functional Group.* Column 2 lists the next higher assembly group and the item names of components, assemblies, subassemblies, and modules within the group for which maintenance is authorized.

*c. Maintenance Functions.* Column 3 lists the maintenance functions defined in paragraph E-2 above.

*d. Maintenance Category.* Column 4 lists the level of each maintenance function required for an item and the time required to perform that task as defined in subparagraph e below.

*e. Work Measurement Time.* The active repair time required to perform the maintenance function is included directly below the level responsible for the appropriate maintenance function. The skill levels used to obtain the measurement times approximate those found in typical TOE units. Active repair time is the average aggregate time required to restore an item (subassembly, assembly, component, module, end item, or system) to a serviceable condition under typical field operating conditions. This time includes preparation time, fault isolation/diagnostic time, and QA/QC time in addition to the time required to perform specific maintenance functions identified for the tasks authorized in the maintenance functions identified for the tasks authorized in the maintenance allocation chart. This time is expressed in man-hours and carried to one decimal place (tenths of hours).

*f. Tools and Equipment.* This column is used to specify, by code, those tools and equipment required to perform the designated function.



**MAINTENANCE ALLOCATION CHART for  
TSGMS CALIBRATION KIT**

(1) GROUP NUM- BER	(2) COMPONENT/ASSEMBLY	(3) MAINTENANCE FUNCTION	(4) MAINTENANCE CATEGORY*					(5) TOOLS AND EQUIP- MENT
			C	O	F	H	D	
01	TSGMS Calibration Kit	Inspect Service			.4			1a
					.4			1a
	Calibration control				3			1a, b
	TSEM shear pin calibration tester							1
	Optical adapter							2
	Unshorting cap					.5		1a
Carrying case				1		1a		

\* C - operator/crew    O - organizational    F - direct support    H - general support    D - depot

END ITEM: TSGMS Calibration Kit

TOOL AND TEST EQUIPMENT REQUIREMENTS

Tool or Test Equipment Reference Code	Maintenance Category	Nomenclature	National/NATO Stock Number	Tool Number
1a	F	Tool Kit Calibration Technician	4935-00-670-7123	
1b	F	Calibration Standards Set Secondary Reference	4931-00-621-7878	
1	L	Requires factory repair		
2	L	Return to USATSG for repair or service		

## APPENDIX F

## PRIOR MODIFICATIONS/ALTERATIONS

---

**Alterations Required for Calibration Kits APN 7915881 Fielded prior to October 1982.**

1. This field change provides instructions to eliminate an intermittent "skip bounce" occurring when calibrating the counter timer in the Monitor and Control Unit of Test Set, Guided Missile System (TSGMS).
2. Refer to figure F-1 for modification of the Time Interval Start-Stop circuit in accordance with steps **a** and **b** below:
  - a. Remove the short jumper wire connected between resistor R14 and the junction of resistors, R19, R20, R21, and R22.
  - b. Install an insulated jumper wire from the junction of R19, R20, R21, and R22 to the junction of C6, R18, and VR3.
  - c. Disconnect the wire on pin 25 (10 V) of circuit card connector P101 and, using sleeving to prevent shorting between pins, install this wire on pin 18 (common) of P101.

**NOTE**

**In steps d and e below some of the wiring to the START/STOP switches may be correct in some units prior to modifying, therefore, tracing these wires prior to interchanging is required. Final results after modification should be as shown on figures F-2 and F-3.**

- d. Identify the two wires connected from pins 32 and 33 of P101 to the TIME INTERVAL START switch. Check with an ohmmeter to determine if the START OFF contact is wired to pin 32 and the START ON contact is wired to pin 33. If wired as described, interchange these two wires at the rear of the START switch so that START ON is routed to pin 32 and START OFF is wired to pin 33.
  - e. Identify the wires connected from pins 34 and 35 of P101 to the TIME INTERVAL STOP switch. Check with an ohmmeter to determine if the STOP OFF contact is wired to pin 34 and STOP ON contact is wired to pin 35 of P101. If wired as described, interchange these two wires at the rear of the STOP switch so that STOP ON is routed to pin 34 and STOP OFF is wired to pin 35.
3. To verify proper operation of these changes to the TIME INTERVAL circuit, connect channels A and B of an oscilloscope to TIMER OUTPUT STOP and START, respectively. Set TIME INTERVAL START and STOP switches to OFF. Both channels displayed should be a logic low,  $0 \pm 0.5$  V when the switches are OFF. Set TIME INTERVAL START to ON. Channel B should go from a logic low to high (from  $0 \pm 0.5$  to  $9.5 \pm 0.5$  V). Set TIME INTERVAL STOP switch to ON. Channel A should go from logic low to high (from  $0 \pm 0.5$  to  $9.5 \pm 0.5$  V).
4. Resistors R10 and R11 on circuit card A101 (figure F-1) may also be selected to provide the proper timing signals shown on page 4-4, paragraph 4-4c and d. Typical values may be in excess of 250 k  $\Omega$  on some units.

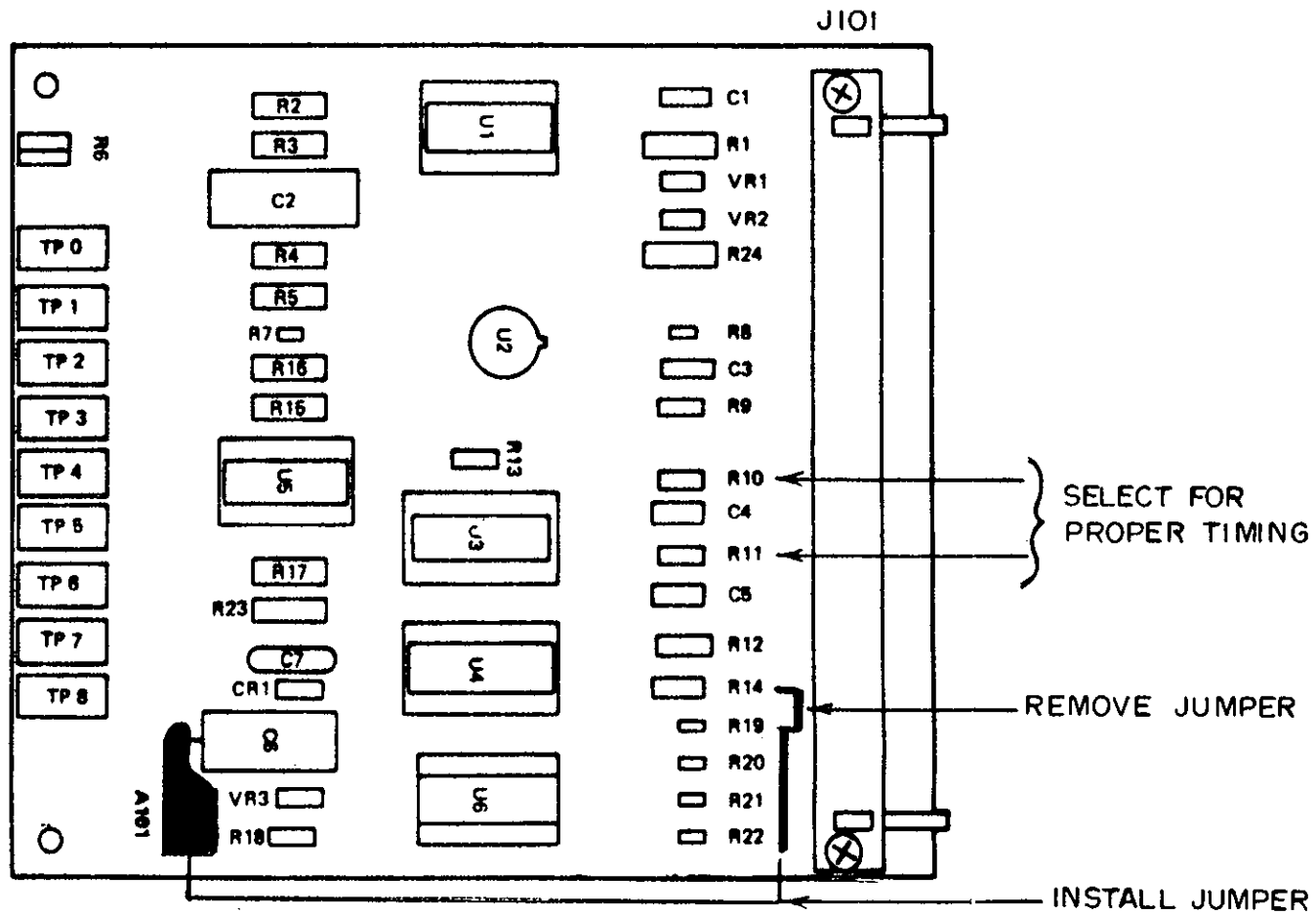

MSCO4341

Figure F-1. CIRCUIT CARD A101 COMPONENT LOCATION

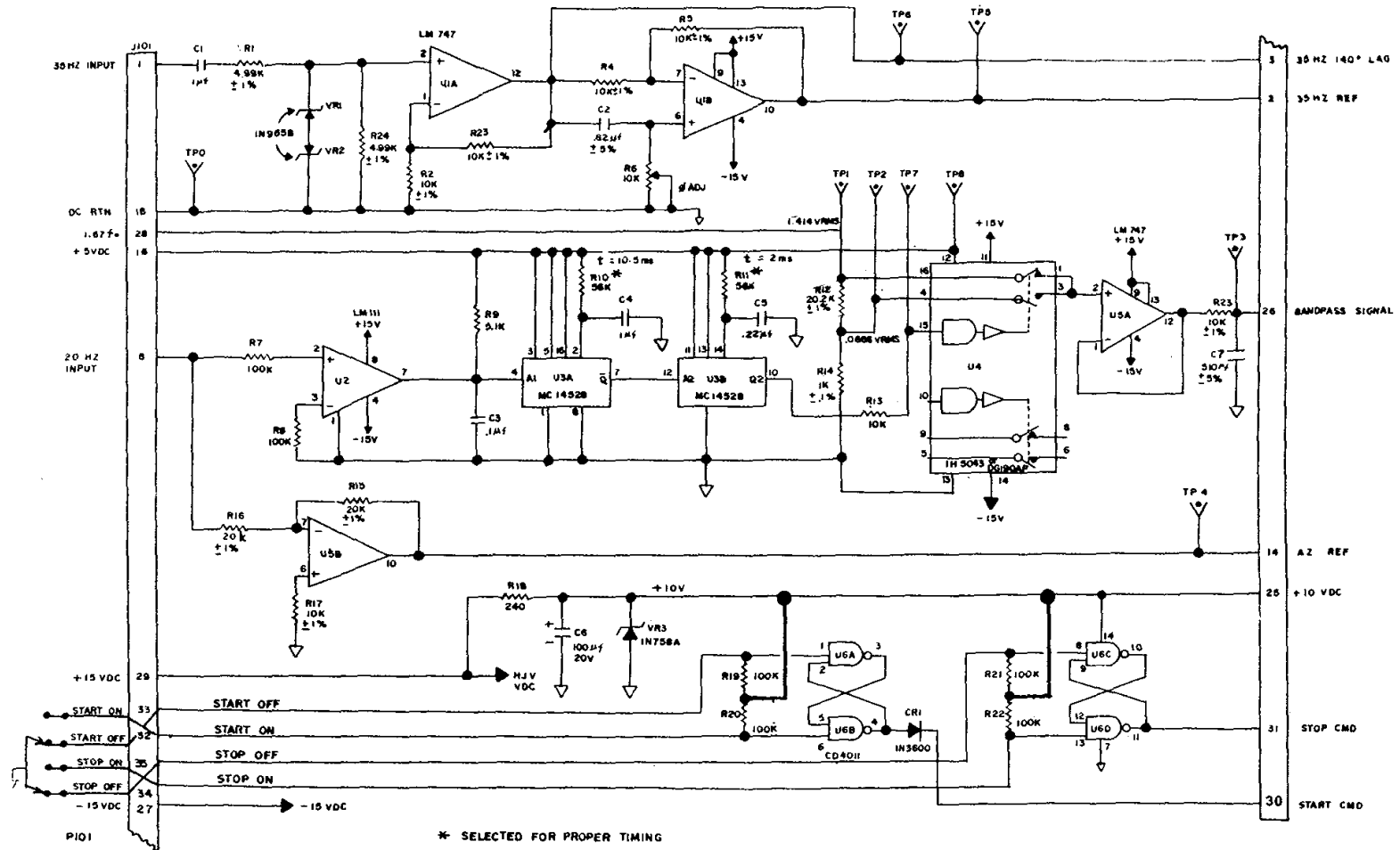

MSC01894

Figure F-2. Circuit card A101 schematic.

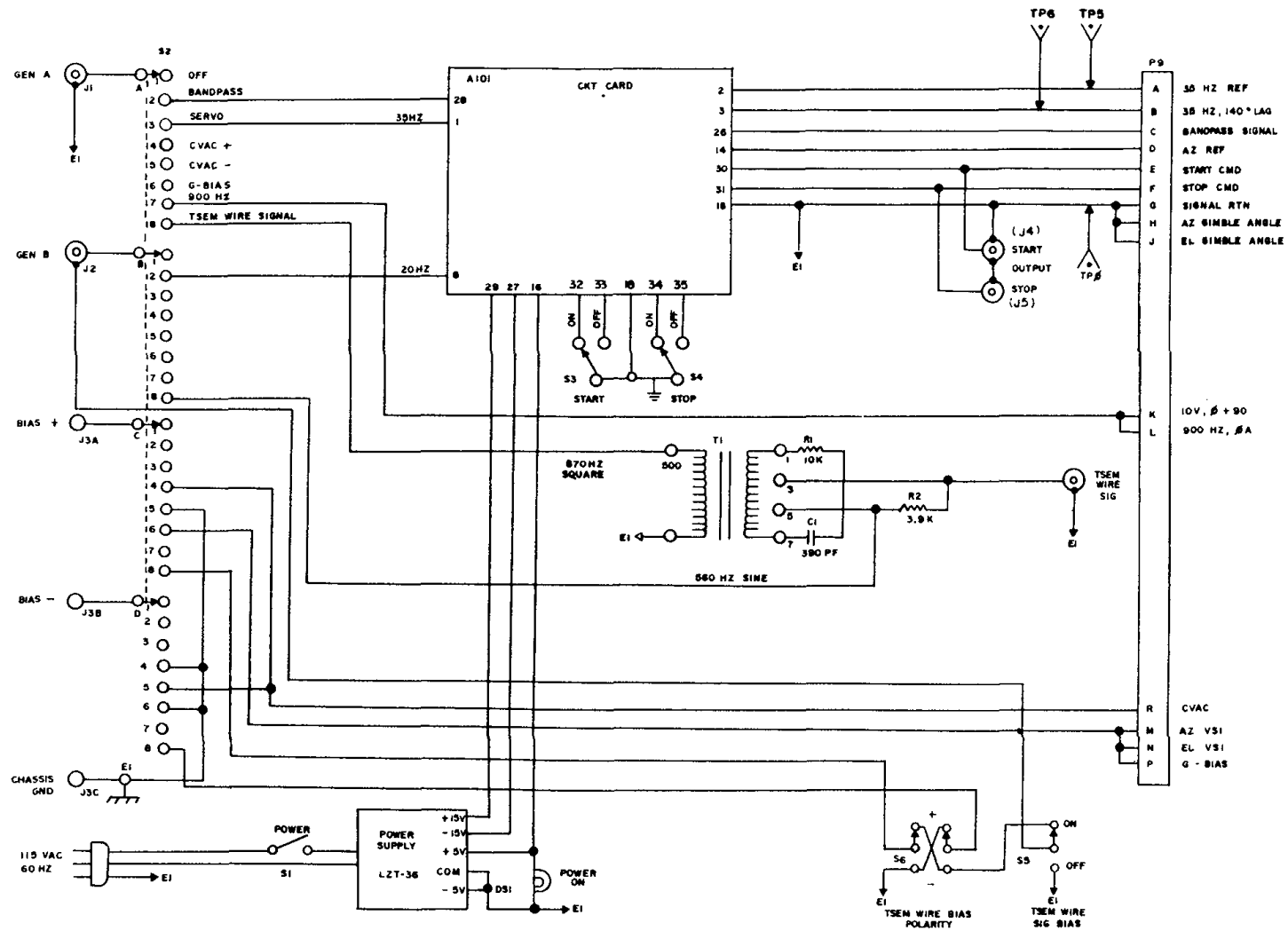

Figure F-3. Calibration control schematic.

RECOMMENDED CHANGES TO EQUIPMENT TECHNICAL MANUALS



**SOMETHING WRONG WITH THIS MANUAL?**

THEN... JOT DOWN THE DOPE ABOUT IT ON THIS FORM, TEAR IT OUT, FOLD IT AND DROP IT IN THE MAIL!

FROM: (YOUR UNIT'S COMPLETE ADDRESS)  
**PFC JOHN DOE**  
**CoA, 3<sup>rd</sup> ENGINEER BN**  
**FT. LEONARD WOOD MO 63108**  
 DATE **16 DEC 74**

PUBLICATION NUMBER **TM5-6115-200-20 AND P** DATE **1 APR 72** TITLE **GENERATOR SET 10 KW**  
**NSN 6115-00-231-7296**

BE EXACT... PIN-POINT WHERE IT IS				IN THIS SPACE TELL WHAT IS WRONG AND WHAT SHOULD BE DONE ABOUT IT:
PAGE NO.	PARA-GRAPH	FIGURE NO.	TABLE NO.	
6	2-1 a			In line 6 of paragraph 2-1a the manual states the engine has <u>6</u> cylinders. The engine on my set only has <u>4</u> cylinders. Change the manual to show <u>4</u> cylinders.
81		4-3		Callout <u>B</u> on figure 4-3 is pointing at a <u>bolt</u> . In the key to fig. 4-3, item 16 is called a <u>shim</u> . Please correct one or the other.
125	line 20			I ordered a gasket, item 19 on figure B-16 by NSN 2910-00-762-3001. I got a gasket but it doesn't fit. Supply says I got what I ordered so the NSN is wrong. Please give me a good NSN.

TYPED NAME, GRADE OR TITLE, AND TELEPHONE NUMBER **JOHN DOE, PFC (268) 317-7111** SIGN HERE: **John Doe**

DA FORM 2028-2 (TEST) P.S.--IF YOUR OUTFIT WANTS TO KNOW ABOUT YOUR MANUAL "FIND" MAKE A CARBON COPY OF THIS AND GIVE IT TO YOUR HEADQUARTERS.

FILL IN YOUR UNIT'S ADDRESS

FOLD BACK

DEPARTMENT OF THE ARMY  
CO A, 3d Engineer Bn  
Ft Leonard Wood, MO 63108

POSTAGE AND FEES PAID  
DEPARTMENT OF THE ARMY  
DOD 314



OFFICIAL BUSINESS  
PENALTY FOR PRIVATE USE \$300

Commander  
US Army Troop Support Command  
Attn: AMSTS-MPP  
4300 Goodfellow Boulevard  
St. Louis, Missouri 63120

CUT ALONG DOTTED LINE

FOLD BACK

REVERSE OF DA FORM 2028-2 (TEST)

REVERSE OF DA FORM 2028-2 (TEST)





FILL IN YOUR  
UNIT'S ADDRESS

FOLD BACK

DEPARTMENT OF THE ARMY

POSTAGE AND FEES PAID  
DEPARTMENT OF THE ARMY  
DOD-314

OFFICIAL BUSINESS  
PENALTY FOR PRIVATE USE, \$300

Commander  
US Army TMDE Support Group  
ATTN: DRXTM-LML  
Redstone Arsenal, AL 35898

TEAR

DOTTED LINE

FOLD BACK

By Order of the Secretary of the Army:

**JOHN A. WICKHAM, JR.**  
*General, United States Army*  
*Chief of Staff*

Official:

**ROBERT M. JOYCE**  
*Major General, United States Army*  
*The Adjutant General*

Distribution:

To be distributed in accordance with Std. IDS No. RLC-1500, 9 September 1982.

